





Technical data	Application
<b>Operating voltage:</b>	230 V / 50 / 60 Hz
<b>Temperature sensor:</b>	47 k NTC (external) / 47 k NTC (internal)
<b>Changeover sensor:</b>	47 k NTC (external for heating / cooling changeover)
<b>Switching current:</b>	heating 5 (1) A; cooling 5 (1) A; fan 6 (2) A / 230 V ~
<b>Contact:</b>	relay (1 make contact each for heating / cooling)
<b>Heating / cooling changeover</b>	via an external changeover sensor or via contact
<b>Setting ranges:</b>	5 ... 30°C
<b>Switching difference:</b>	approx. 1 K
<b>Neutral zone:</b>	approx. 2 K, permanently
<b>Switch:</b>	ON / OFF, 3-stage fan
<b>Degree of protection:</b>	IP 30, after acc. installation
<b>Protection class:</b>	II, after acc. installation
<b>General equipment:</b>	mechanical range suppression; Jumper: ext. / int. sensor Jumper: heating <b>and</b> cooling (4-pipe systems) / heating <b>or</b> cooling (2-pipe systems); Jumper: fan ON / OFF within the neutral zone
<b>Admissible air moisture:</b>	max. 95 % r.h., non condensing
<b>Storage temperature:</b>	-20 ... +70°C
<b>Radio interference suppression:</b>	acc. to EN 60730
<b>Ambient temperature:</b>	0 ... 30°C
<b>Housing colour:</b>	pure white, similar to RAL 9010
<b>Housing material:</b>	plastic (ABS)
<b>Mounting / installation:</b>	surface installation / wall mounting
<b>Weight:</b>	device: approx. 250 g / sensor: approx. 150 g
<b>Electrical connections:</b>	terminal screws

Control of climates in individual rooms. Device with neutral zone for the control of 2- or 4-pipe air conditioning systems.

Regarding sensors, see as of page 99.

See also "General technical information" as of page 164.

Model / Picture	Item No.	Equipment	Sensor	Circuit diagram	PG
<b>KTRRB-112.135</b> 	MA 600800 <b>New</b>  Replaces METR 75.836 / 3	Climate controller with 3-stage fan output and inlet (e. g. via window contact) for external excitation. "Off plus frost protection monitoring" (terminals 14 / 13): contact closed = normal operation; contact open = operation in frost protection mode. Heating / cooling changeover triggered via external changeover sensor or via contact (terminals 16 / 15): contact closed = heating; contact open = cooling. Room frost protection function active with ON / OFF switch in OFF position.	internal or external sensor (the temperature and changeover sensors HF-2, LF-22 or ALF-2) are <b>not</b> included in the scope of the delivery	see next page	A
<b>KTRRB-112.136</b> 	MA 600900 <b>New</b>  Replaces 75.836 / 4	Climate controller with 3-stage fan output and inlet (e.g. via window contact) for external excitation. ECO mode (terminals 14 / 13): contact closed = normal operation; contact closed = ECO mode operation. The neutral zone (2 K) is, during operation in ECO mode, enlarged by ±3 K. The ECO mode is a special energy economizing mode that should either be controlled through a window contact or a switch clock; heating / cooling changeover triggered via external change-over sensor or via contact (terminals 16 / 15): contact closed = heating; contact open = cooling). Room frost protection function active with ON / OFF switch in OFF position.	internal or external sensor (the temperature and changeover sensors HF-2, LF-22 or ALF-2) are <b>not</b> included in the scope of the delivery	see next page	A

# Electronic climate controllers

For surface installation – Design Berlin 3000



Model / Picture	Item No.	Equipment	Sensor	Circuit diagram	PG
<b>JZ-17</b>	MN 990001 <b>New</b>	Adapter plate for installation on an UP box (incl. fixing screws for installation of the KTRRB on the adapter plate)			K

Additional climate controllers in preparation – see overview of climate controllers on page 52, for electronic climate controllers see as of page 38 and for flush mounted climate controllers as of page 44

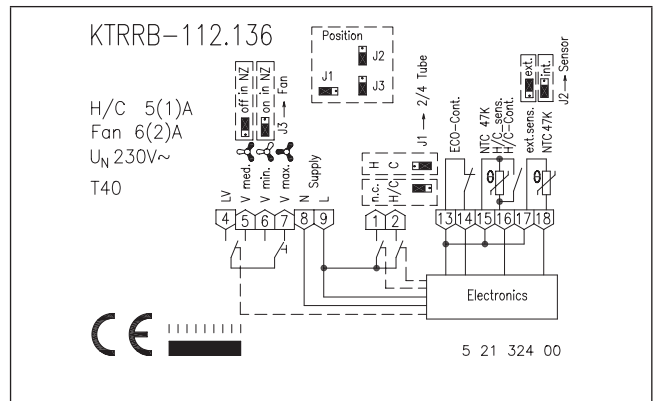
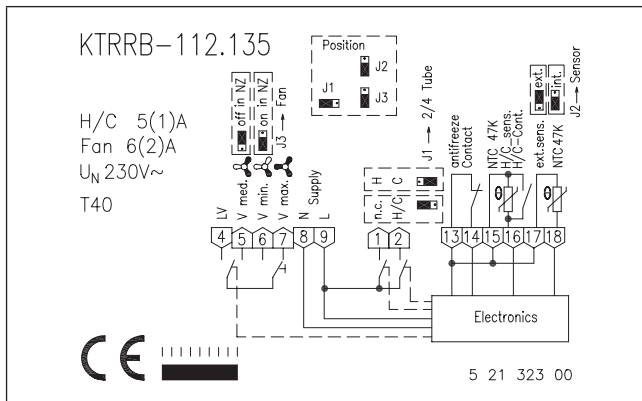
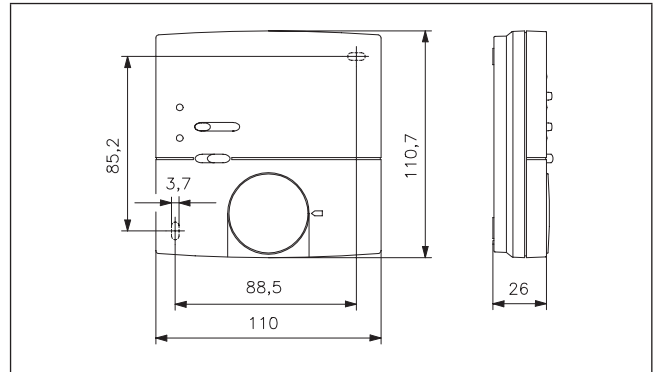

# Electronic cooling ceiling controllers

For surface installation – Design Berlin 2000



## Technical data

<b>Operating voltage:</b>	24 V~ / = approx. 1 VA safety extra low voltage
<b>Sensor:</b>	internal, NTC (47 kΩ) external flow sensor, NTC (47 kΩ) (changeover sensor), external dew point sensor (TPS)
<b>Switching current:</b>	1A / 24 V~ (max. 32 VA)
<b>Switching contact:</b>	relay / make contact
<b>Setting ranges:</b>	5 ... 30°C; 21° ± 8 K
<b>Switching difference:</b>	approx. 1 K
<b>Degree of protection:</b>	IP 30
<b>Protection class:</b>	III
<b>General equipment:</b>	mechanical range suppression
<b>Indicators (LEDs):</b>	see "Equipment"
<b>Switch:</b>	see "Equipment"
<b>Admissible air moisture:</b>	max.95 % r.h., non condensing
<b>Storage temperature:</b>	-20 ... +70°C
<b>Radio interference suppression:</b>	acc. to EN 60730
<b>Ambient temperature:</b>	0 ... 50°C
<b>Housing colour:</b>	pure white, similar to RAL 9010
<b>Housing material:</b>	plastic (ABS)
<b>Mounting / installation:</b>	surface installation / wall mounting
<b>Weight:</b>	approx. 130 g
<b>Electrical connections:</b>	terminal screws

## Application

Control of temperatures that exist at cooling ceilings and walls and/or in warm water heating systems.

For flush mounted cooling ceiling controllers see page 44.

Both the dew point sensor (see page 45) and the changeover sensor "2" (see "Sensor Technology" as of page 99) **need to be ordered separately!**

### Model / Picture

### Equipment

### Sensor

### Circuit diagram

### PG

**KTRRB-042.211**  
DA 420000

**Setting range (turning knob):** 21°C ± 3 K  
The factory preset "zero" (21°C) can be changed internally by ± 5K.  
**Outputs:** Relay output "cooling and heating".  
Heating / cooling hysteresis: approx.1 K.  
**Inputs:** Internal sensor (NTC 47 kΩ)  
Dew point sensor (TPS) for cooling mode interruption (max. 5 dew point sensors can be operated in parallel).  
**Scale:** Relative scale (set value 21°C with "0" marking and swelling arrows "+" for warmer and "-" for colder)  
**Indications:**  
Two-colour LED indicator on the left:  
red for "heating" or green for "cooling"  
Two-colour LED indicator on the right:  
red for "dew point" or green for "ON"  
**Functions:** Heating and cooling with adjustable neutral zone. Cooling mode interrupted in the event the dew point sensor detects the condensation of moisture.  
**Adjustments:** neutral zone ± 0.5 ... 2.5 K  
(± 0.5 K, factory setting)  
**Application:** Control of temperatures in individual rooms. The device is equipped with a relay output for the actuation of the valves which are employed for the control of climates produced by **4-pipe systems** (with adjustable neutral zone and interruption of the cooling operation in the event the external dew point sensor detects the condensation of moisture).

internal  
dew point  
sensor

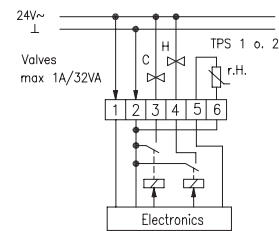



A



Replaces  
PETR 75.873 / 1

# Electronic cooling ceiling controllers

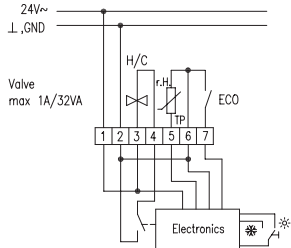
For surface installation – Design Berlin 2000

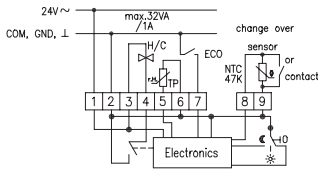
Model / Picture	Equipment	Sensor	Circuit diagram	PG
<b>KTRRB-040.112</b> DA 420100 	<b>Control range:</b> 5...30°C <b>Output:</b> Relay output “cooling or heating”. Heating / cooling hysteresis: approx. 1 K <b>Inputs:</b> Internal sensor (NTC 47 KΩ), Dew point sensor (TPS) for cooling mode interruption (max. 5 dew point sensors can be operated in parallel). External contact for ECO function triggering. <b>Switch:</b> “Cooling / heating changeover”. <b>Scale:</b> 5...30°C, mechanical range suppression <b>Indications:</b> Two-colour LED indicator on the left: red for “heating” or green for “cooling” Two-colour LED indicator on the right: red for “dew point” and green for “ECO” <b>Functions:</b> Heating or cooling (can be switched over manually); ECO function (temperature decrease when heating and temperature increase when cooling), can be triggered via an external contact (terminal 7). Interruption of the cooling operations in the event of moisture condensation. <b>Adjustments:</b> ECO zone ±0.5...2.5 K (± 1 K, factory setting) <b>Application:</b> Control of the temperatures in individual rooms. The device is equipped with a relay output for the control of the related valves (manually switchable cooling / heating control).	internal dew point sensor		A
<b>KTRRB-040.213</b> DA 420200 	<b>Setting range (turning knob):</b> 21°C ± 3 K, the factory preset “zero” (21°C) can be adjusted internally by ± 5 K. <b>Outputs:</b> Relay output “cooling or heating”. Cooling / heating hysteresis: approx. 1 K <b>Inputs:</b> Internal sensor (NTC 47 kΩ). Dew point sensor (TPS) for cooling mode interruption (max. 5 dew point sensors can be operated in parallel). Changeover sensor or changeover contact for cooling/ heating changeover. External contact for ECO function triggering. <b>Switch:</b> “OFF (forced switch off) / day / ECO” <b>Scale:</b> Relative scale (set value 21°C with “0” marking and swelling arrows (“+” for warmer and “-” for colder) <b>Indications:</b> Two-colour LED indicator on the left: red for “heating” or green for “cooling” Two-colour LED indicator on the right: red for “dew point” and green for “ECO” <b>Functions:</b> Switchable between heating or cooling via an external changeover sensor or changeover contact. ECO function (temperature decrease when heating, temperature increase when cooling), can be triggered via an external contact (terminal 7). Forced switch off can be activated via switch operation (position “0”). Frost protection monitoring of rooms at approx. 5°C. Interruption of the cooling operations in the event of moisture condensation. <b>Adjustments:</b> ECO zone ±0.5...2.5 K (± 1 K, factory setting) <b>Application:</b> Control of temperatures in individual rooms. The device is equipped with a relay output that enables to trigger the changing between the cooling and heating control operations through the operation of a changeover sensor or a changeover contact. Additionally equipped with an “ECO and forced switch off function” switch and an external contact for the triggering of the ECO function.	internal dew point sensor/ change over sensor, e.g. HF-2, ALF-2		A

**Note:** For flush mounted cooling ceiling controllers see as of page 44.

