

## Selection

k <sub>VS</sub> [m³/h]	DN		Type			Suitable rotary actuators					
	mm	Inches	Internal thread	External thread	Flange	Modulating DC 0...10 V	3-point	Emerg. control function			
0.25	10	3/8"	R205K	R405K	–	TRD24-SR AC/DC 24 V	TRD24-3 AC 24 V				
0.4	10	3/8"	R206K	R406K	–						
0.63	10	3/8"	R207K	R407K	–						
1	10	3/8"	R208K	R408K	–						
1.6	10	3/8"	R209K	R409K	–						
0.63	15	1/2"	R209	R409	R609R	TR24-SR AC/DC 24 V	TR24-3 AC 24 V				
1	15	1/2"	R210	R410	R610R						
1.6	15	1/2"	R211	R411	R611R						
2.5	15	1/2"	R212	R412	R612R						
4	15	1/2"	R213	R413	R613R						
6.3	15	1/2"	R214	R414	R614R						
4	20	3/4"	R217	R417	R617R				LR24-SR AC/DC 24 V	NR24-3 AC 24 V	
6.3	20	3/4"	R218	R418	R618R						
8.6	20	3/4"	R219	R419	R619R						
6.3	25	1"	R222	R422	R622R						
10	25	1"	R223	R423	R623R	NR230-3 AC 230 V	LF24-SR AC/DC 24 V				
16	25	1"	R224	R424	R624R						
10	32	1 1/4"	R229	R429	–	NR(Y)24-SR AC/DC 24 V	AFR24-SR AC/DC 24 V				
16	32	1 1/4"	R231	R431	R631R						
16	40	1 1/2"	R238	R438	R638R						
25	40	1 1/2"	R239	R439	R639R						
25	50	2"	R248	R448	R648R						
40	50	2"	R249	R449	R649R						
58	65	2 1/2"	–	–	R664R						
90	80	3"	–	–	R679R						



2-way characterized control valves  
DN 10...80



For modulating control of cold and hot water

Equal-percentage characteristic

## Applications

- Water-side control of air handling apparatus in ventilation and air-conditioning systems
- Water-side control in heating systems

## Mode of operation

The characterized control valve is operated by a rotary actuator. The actuators are controlled by a standard modulating or 3-point control system and move the ball of the valve – the throttling device – to the opening position dictated by the control signal.

## Product features

**Equal-percentage characteristic** of the flow rate ensured by the integral characterizing disc.

**Manual operation by lever** after disengaging the gearing latch on the Type TR.., LR.. or NR.. rotary actuator (manual operation not possible with LF./AFR..).

## Ordering

An order for an R2.. characterized control valve includes a suitable rotary actuator.

### Ordering examples: (with NR24-SR)

- R231 characterized control valve with NR24-SR
  - Rotary actuator fitted
  - Order code: R231+NR24-SR
- R231 characterized control valve and NR24-SR
  - Rotary actuator supplied separately
  - Order code: R231/NR24-SR

## Technical data

Flow media	Cold and hot water, Water with max. 50% volume of glycol
Temperature of medium	+5 °C...+110 °C (lower or higher temperatures on request)
Rated pressure p <sub>s</sub>	See table below
Flow characteristic	Control path A–AB: equal percentage (to VDI/VDE 2173) DN 10...15* n(gl) = 3.2, optimized in opening range DN 20...50** n(gl) = 3.9, optimized in opening range
Rangeability	DN 10...15* Sv > 50 DN 20...50** Sv > 100
Leakage rate	Air bubble-tight (BO 1, DIN 3230 Part 3)
Pipe connector	R2.. internal thread to ISO 7/1 R4.. external thread to ISO 228/1 R6.. flange PN 6 to EN 1092/1
Differential pressure Δp <sub>max</sub>	350 kPa (200 kPa for low-noise operation)
Closing pressure Δp <sub>s</sub>	1400 kPa
Angle of rotation	90°(operating range 15°...90°)
Installation position	Upright to horizontal (in relation to the stem)
Maintenance	Maintenance-free

## Materials

Fitting	Forged, nickel-plated brass body
Valve cone	Stainless steel / R6.. chrome-plated brass
Seal	PTFE
Stem	Stainless steel / R6.. chrome-plated brass
Stem seal	EPDM
Flange ring	DN 15/20 Zinc-plated steel DN 25...80 Aluminum
Flange joint surface	Nickel-plated brass
Characterizing disk	TEFZEL

\* Up to k<sub>VS</sub> 2.5 \*\* And DN15 k<sub>VS</sub> > 4

Type	Rated pressure p <sub>s</sub> [kPa]
R205.. – R229	4140
R405.. – R429	4140
R231 – R249	2760
R431 – R449	2760
R609R – R679R	600

## Important

- Sizing diagram for characterized control valves: page 7
- Dimensions: pages 12, 33, 34 and 36
- Installation instructions: pages 33, 34, 36
- Please note the information provided on pages 2 and 38 to 40 regarding use, installation, project design, commissioning and maintenance
- Pipe connectors can be supplied as an accessory: page 13

## 2-way ball valves with internal thread

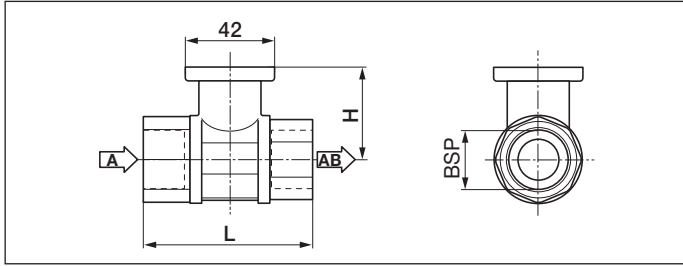

DN	Dimensions		Thread		Weight
	L	H	BSP	Max. screwing depth	
[mm]	[mm]	[mm]	[Inches]	[mm]	[kg]
10	52	35	3/8"	10	0.3
15	67	45	1/2"	13	0.4
20	78	47.5	3/4"	13	0.55
25	87	47.5	1"	17	0.7
32	105	47.5	1 1/4"	19	0.9
32	105	52	1 1/4"	19	1.05
40	111	52	1 1/2"	19	1.15
50	125	58	2"	22	1.8

## 2-way ball valves with external thread

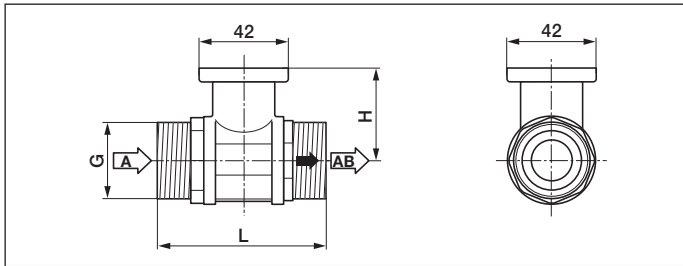

DN	Dimensions		Thread	Weight
	L	H	G	
[mm]	[mm]	[mm]	[Inches]	[kg]
10	69	31.5	3/4"	0.4
15	74	44	1"	0.6
20	85.5	46	1 1/4"	0.8
25	84.5	46	1 1/2"	0.9
32	97.5	46	2"	1.1
32	102	50.5	2"	1.3
40	103	50.5	2 1/4"	1.4
50	115.5	56	2 3/4"	2.3

## 2-way ball valves with flanges

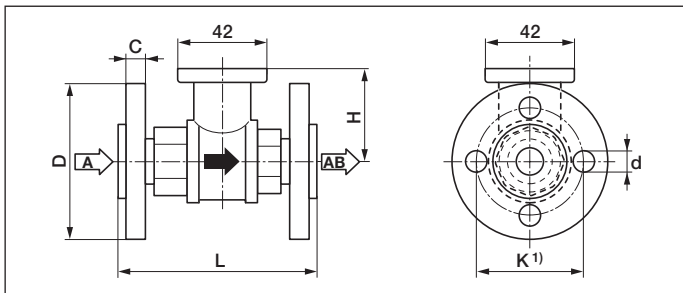

DN	Dimensions		Flange				Weight
	L	H	D	C	K	d	
[mm]	[mm]	[mm]	[mm]	[mm]	[mm]	[mm]	[kg]
15	101.5	45	80	15	55	4 x 11	1.3
20	112	47.5	90	15	65	4 x 11	1.7
25	132	47.5	100	20	75	4 x 11.5	1.7
32	143.5	52	120	17	90	4 x 14	2.3
40	149.5	52	130	18	100	4 x 14	2.7
50	165	58	140	18	110	4 x 14	3.7
65	180.5	69	160	18	130	4 x 14	6.0
80	191.5	69	190	20.5	150	4 x 18	7.6

## Sizing diagram Characterized control valves

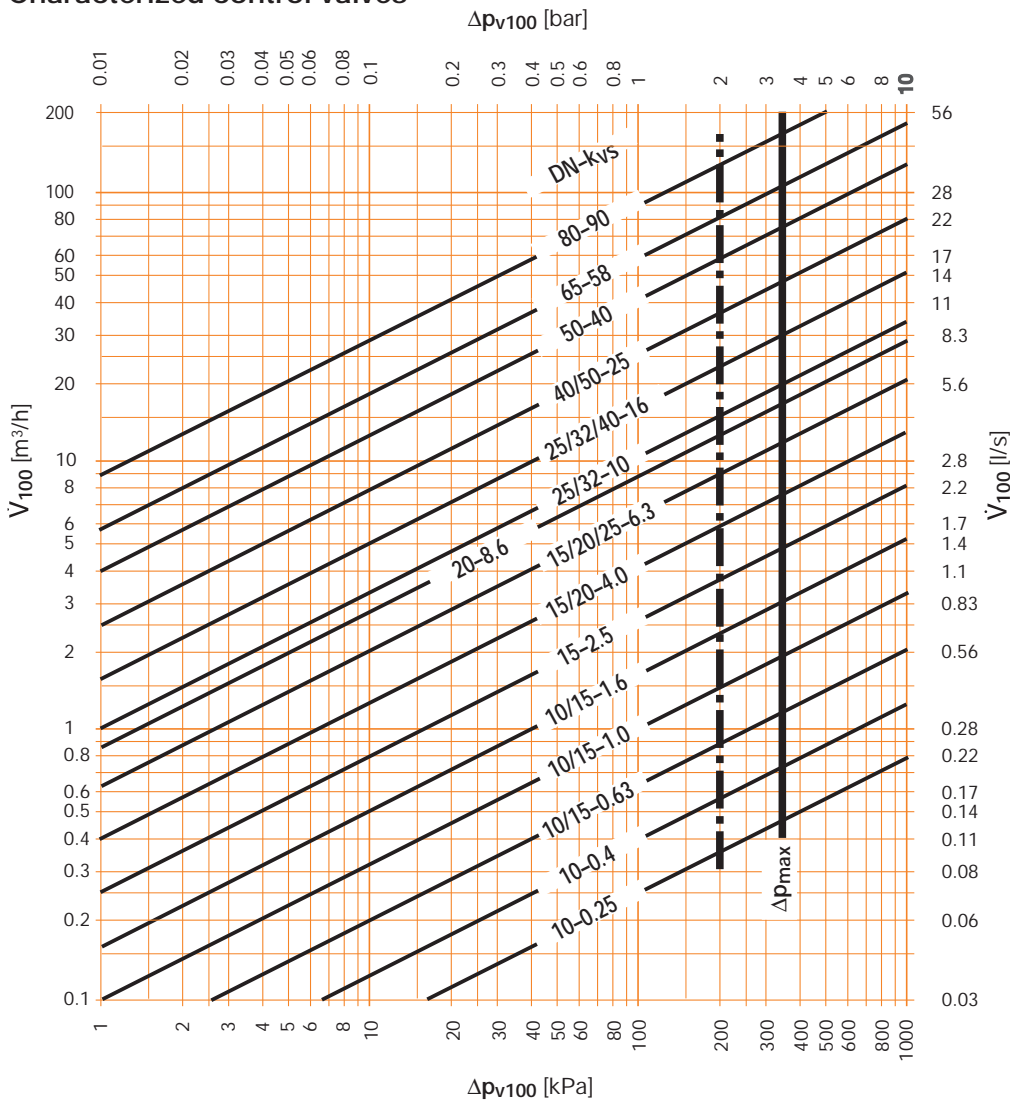

### Legend

- $\Delta p_{max}$**   
Maximum permitted pressure difference for a long service life across control path A-AB referred to the whole range of opening
- - -  $\Delta p_{max}$**   
For low-noise operation
- $\Delta p_{v100}$**   
Pressure difference with ball valve fully open
- $V_{100}$**   
Nominal flow rate with  $\Delta p_{v100}$

### Formula $k_{vs}$

$$k_{vs} = \sqrt{\frac{\dot{V}_{100}}{\frac{\Delta p_{v100}}{100}}}$$

$k_{vs}$  [m³/h]  
 $\dot{V}_{100}$  [m³/h]  
 $\Delta p_{v100}$  [kPa]

### Definition of $\Delta p_s$

Closing pressure at which the actuator can still seal the valve tightly allowing for the appropriate leakage rate

## Sizing table Open-close ball valves

Differential pressure $\Delta p_{v100}$ [kPa]	Connection				$k_{vs}$ [m³/h]	DN [mm]	2-way 	3-way 
	0.1	1	3	10				
Flow rate $\dot{V}_{100}$ [m³/h]	0.27	0.86	1.49	2.72	8.6	15	R215 R415 R615R	R315 R515 R715R
	0.66	2.1	3.6	6.6	21	20	R220 R420 R620R	R320 R520 R720R
	0.82	2.6	4.5	8.2	26	25	R225 R425 R625R	R325 R525 R725R
	0.51	1.6	2.77	5.06	16	32	R230 R430	R330 R530
	1.01	3.2	5.54	10.12	32	32	R232 R432 R632R	R332 R532 R732R
	1.01	3.2	5.54	10.12	32	40	R240 R440 R640R	R340 R540 R740R
	1.55	4.9	8.49	15.5	49	50	R250 R450 R650R	R350 R550 R750R
	5.05	16	27.73	50.63	160	65	R665R	-
	5.05	16	27.73	50.63	160	80	R680R	-

## Ordinary ball valves are unsuitable as control devices

In order to ensure good stability of control, a hydraulic final controlling element must possess a flow characteristic that supplements the non-linear characteristic of the heat exchanger in the HVAC system.

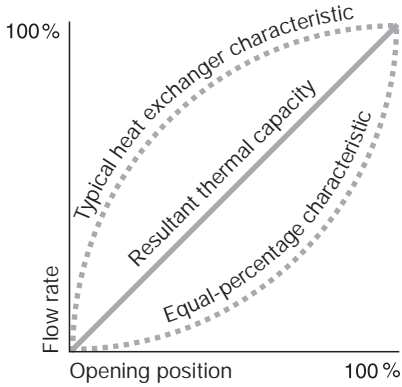

Characteristics of an ideal hydraulic final controlling element

An equal-percentage valve characteristic is desirable in order to produce a linear relationship between the thermal output and the opening position of the final controlling element. This means that the flow rate increases very slowly as the final controlling element begins to open.

Unfortunately, this characteristic is severely distorted in ordinary ball valves.

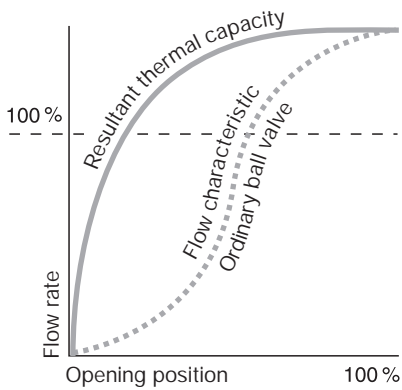

Characteristic of an ordinary ball valve

The reason for this is that an ordinary ball valve has an extremely high flow coefficient ( $k_{VS}$  value) compared with its nominal size, several times that of a comparable globe valve.

Therefore, an ordinary ball valve is not very suitable for performing control functions:

- Flow coefficient excessive due to the design
- Flow control inadequate in the part-load range

## Belimo adds "characterized control" to ball valves

Belimo has succeeded in solving the problem of the distorted flow characteristic of ordinary ball valves.

A so-called "characterizing disc" in the inlet of the characterized control valve converts the valve's characteristic to the equal-percentage kind.

The side of the characterizing disc facing the ball is concave and in contact with the surface of the ball. Thus, the actual flow is regulated by the hole in the ball and by the V-shaped aperture in the characterizing disc.

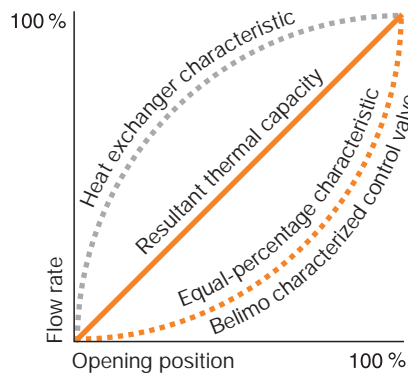

Characteristic of a Belimo characterized control valve

The  $k_{VS}$  value is reduced and corresponds approximately to that of a globe valve of comparable size. In order to avoid having to fit pipe reducers in the majority of cases, each valve size is also available with an appropriate choice of  $k_{VS}$  values.

## Advantages of the Belimo characterized control valve

- Equal-percentage characteristic
- No initial jump in flow on opening
- Excellent stability of control thanks to the characterizing disc

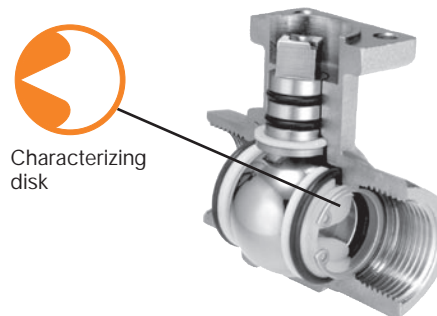

- $k_{VS}$  values similar to those of globe valves of comparable size
- Fewer pipe reducers needed
- Better part-load characteristics and less prone to vibration, greater stability of control
- Tight-sealing (2-way)

## Elements of the characterized control valve

- 1 Simple direct mounting using a central screw. The rotary actuator can be mounted in four different positions
- 2 Square stem head for form-fit attachment of the rotary actuator
- 3 Identical mounting flange for all sizes
- 4 Stem with two O-ring seals for a long service life
- 5 Ball and stem made of stainless steel

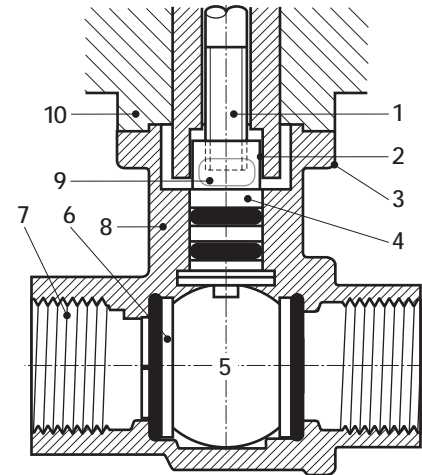

- 6 Characterizing disc produces equal-percentage flow characteristic
- 7 Internal thread connection (ISO 7/1)
- 8 Forged fitting, nickel-plated brass body
- 9 Vent window to prevent the accumulation of condensation
- 10 Thermal decoupling of the actuator from the ball valve

## Optimum choice of $k_{VS}$ valves of identical size

- Better controllability
- Lower installation costs

The Belimo range of characterized control valves includes 2-way and 3-way types. These are available in a variety of sizes and with a choice of  $k_{VS}$  values.

A characterized control valve is supplied as a unit complete with a suitable Belimo rotary actuator.