

m0031912

Application

The ZG-AF mounting accessory is used for fitting this type of spring return actuator and for actuating safety dampers when it is impossible to mount the actuator directly on the damper spindle.

Kit specification

- ① – Front mounting bracket
- ② – Rear mounting bracket
- ③ – Crank arm AF
- ④ – 2 ball joints KG8
- ⑤ – 4 mounting brackets
 - 2 screws M6 x 16
 - 2 screws M6 x 65 with nuts
 - 5 self-tapping screws
- ⑥ – Universal crank arm:
order separately, not included with the ZG-AF mounting accessory.

Flat mounting (Fig. 1)

The spring return actuator is attached to the air duct by means of the two brackets.

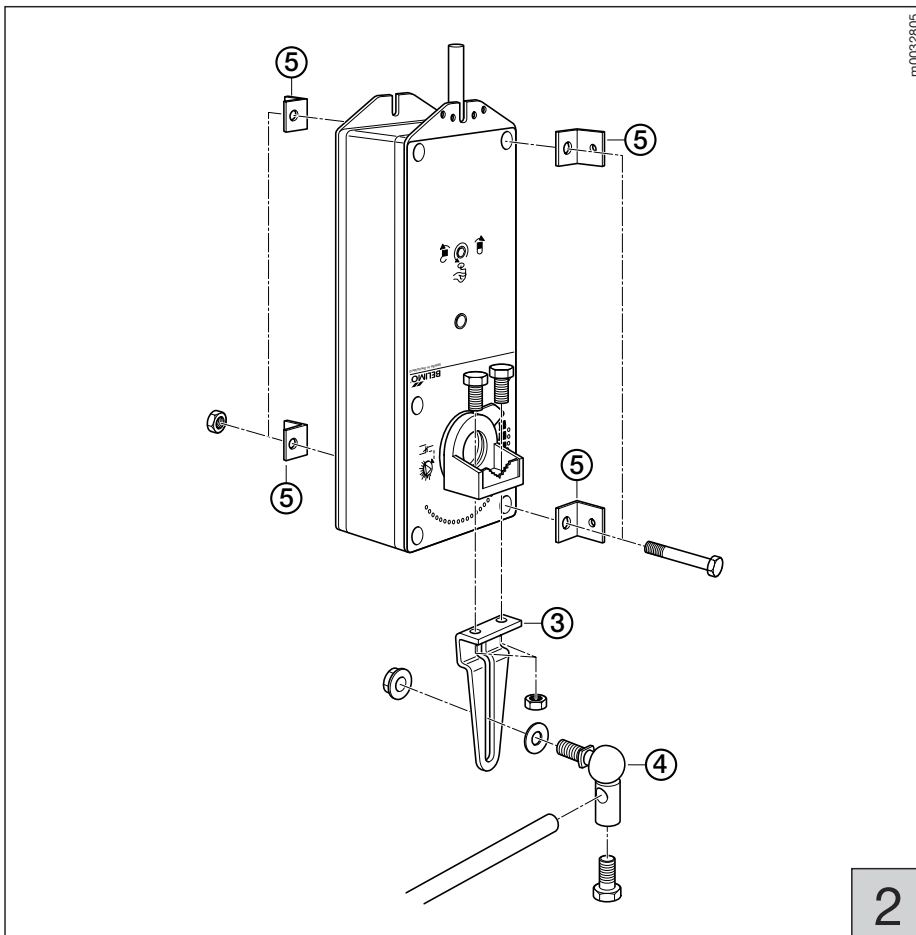

m0032805

Side mounting (Fig. 2)

In this case four identical brackets are used for attaching the actuator instead of the other two brackets.

Linkage mounting (Figs. 1 and 2)

A slotted lever (KH8) is substituted for the U-bolt in the shaft adaptor of the spring return actuator. A second slotted lever is attached to the damper spindle. The rotation of the actuator is transmitted to the damper spindle by means of a connecting rod and two ball joints bolted to the slotted levers.