



## Linear actuators for 2-way and 3-way globe valves DN 65...150

Modulating actuator (AC/DC 24 V)  
Control DC 0...10 V

### Applications

Operation of globe valves.

### Mode of operation

Modulating control is effected by means of a standard 0...10 V control signal.

### Product features

Simple attachment to the neck of the valve by means of a clamping flange. Form-fit coupling of the valve stem to the actuator spindle. The actuator can be rotated through 360° on the neck of the valve.

### Functional reliability

The actuator is short-circuit-proof and protected against polarity reversal. The stroke is adapted automatically and is also overload-proof.

### Manual operation

Inserting a 5 mm hexagonal key and turning it clockwise causes the actuator spindle to extend from the actuator housing (pushing).

Together with the action of the valve, this causes the flow of water to increase. The actuator spindle retains its position until the power supply is energized (the controller takes first priority).

### Position indication

The stroke of the valve is indicated mechanically on the bracket; the maximum stroke adjusts itself automatically. There is a twin-color LED status indicator under the cover of the housing.

### Safety note

The linear actuator contains no components which can be replaced or repaired by the user.

### Note on delivery

The bracket is part of the actuator.

### Dimensions

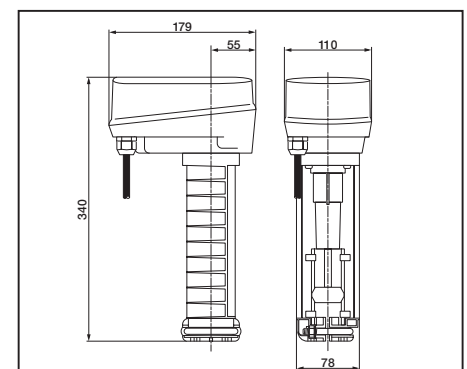

### Wiring diagrams

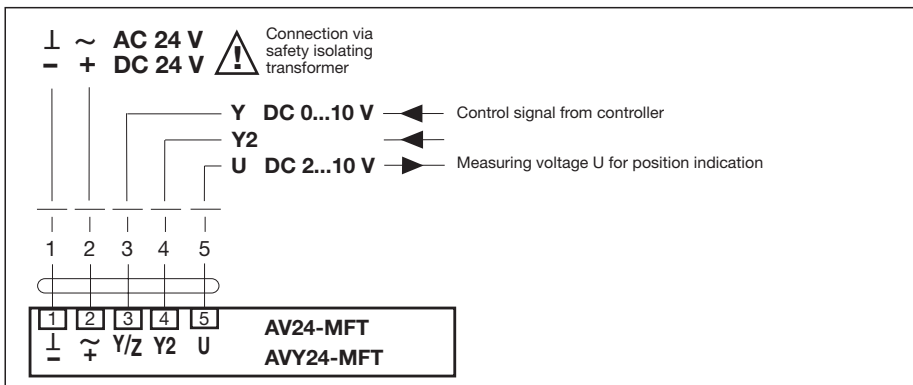

Technical data	AV24-MFT	AVY24-MFT
Nominal voltage	AC 24 V 50/60 Hz, DC 24 V	
Nominal voltage range	AC 19.2...28.8 V, DC 21.6...28.8 V	
For wire sizing	10 VA	
Power consumption	6 W	
Connecting cable	1 m, 5 x 0.75 mm <sup>2</sup>	
Control	DC 0...10 V @ 100 kΩ	
Operating range	DC 2...10 V for 0...100 % stroke	DC 0.5...10 V for 0...100 % stroke
Position feedback	DC 2...10 V @ 0.5 mA	DC 0.5...10 V @ 0.5 mA
Uni-rotation	±5 %	
Nominal stroke	50 mm	
Actuating force	2000 N	
Manual operation	Hexagonal key, self-resetting	
Fast running function	•	
Running time	150 s	60 s
Sound power level	Max. 35 dB (A)	Max. 45 dB (A)
Position indication	Mechanical 20...50 mm stroke	
Protection class	III (safety extra-low voltage)	
Degree of protection	IP54	
Ambient temperature range	0°...+ 50° C	
Non-operating temperature	-40°...+ 80° C	
Humidity test	To EN 60730-1	
EMC	CE according to 89/336/EEC	
Software class A	To EN 60730-1	
Mode of operation	Type 1 to EN 60730-1	
Maintenance	Maintenance-free	
Weight	2.9 kg (without globe valve)	

## Arrangement of the operating controls on the NV../AV.. multifunctional

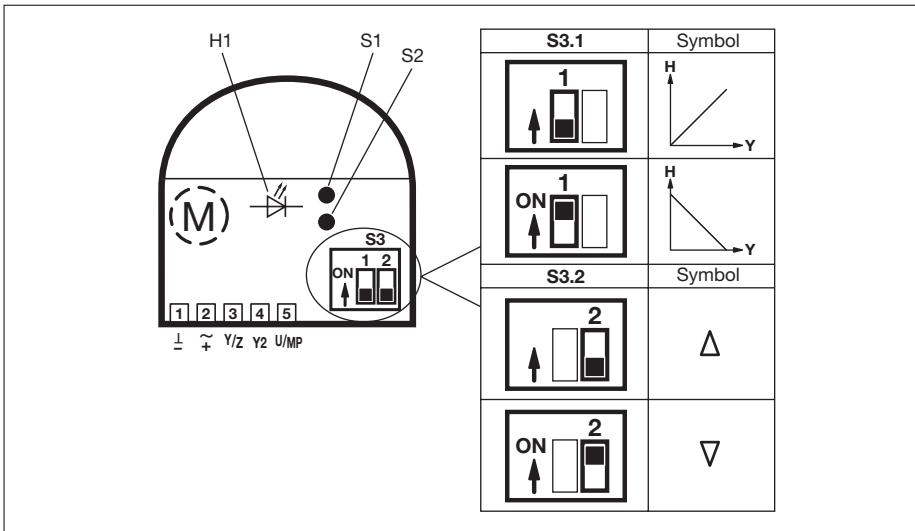

Under the cover of the actuator are the terminals for connecting the lead, the S1, S2 and S3 control devices and the H1 LED indicator.

By setting slide switch S3 or pressing pushbuttons S1 and S2, it is possible to configure the actuator very simply on site to suit actual requirements if changes are necessary from the factory settings.

## Functional description

Function	Description	Switch	Symbol	Bold type in the table means standard factory setting (valve-specific).
Test	The valve effects full stroke with maximum running time and checks the adapted stroke to determine whether the two end-points (H = 0% and H = 100%) are reached.	Press S1		
Init (adaptation)	The possible stroke effected (between the two mechanical end stops of the valve) is detected as 100% stroke and stored in the microprocessor. The control signal and the running time are then matched to this 100% stroke.	Press S2		
Dir. of stroke	Direction of stroke relative to the control signal	S3.1	Symbol	Consequence
<b>Direct</b>	<b>0% control signal corresponds to 0% position feedback. (The actuator spindle is extended or retracted according to the selected closing point.)</b>	<b>OFF</b>		
Inverted	0% control signal corresponds to 100% position feedback. (The actuator spindle is extended or retracted according to the selected closing point.)	ON		
Valve closing point	Closing point with actuator spindle extended or retracted. The valve control path has zero flow.	S3.2	Symbol	Consequence
<b>Up</b>	<b>The actuator spindle is retracted into the actuator and the valve stem is extended from the fitting. The position feedback indicates 0% if the stroke direction is "direct". Default setting for H4..B-, H5..B-, H6..N- and H7..N valves.</b>	<b>OFF</b>		
<b>Down</b>	<b>The actuator spindle is extended from the actuator and the valve stem is retracted into the fitting. The position feedback indicates 0% if the stroke direction is "direct". Default setting for H6..S valves.</b>	<b>ON</b>		

Only authorized and trained persons are allowed to change the settings of slide switch S3 and pushbutton S2.

1) The electrical closing point is either identical to the deenergized position of the actuator spindle or the opposite of this position, depending on the selected emergency control function type (NVF24-MFT-T or NVF24-MFT-E-T). The actuator type is selected according to the valve design and the required NO (valve open when deenergized) or NC (valve closed when deenergized) function.

## LED indicator H1

Green steady light	Actuator working properly
Green flashing light	Test run or adaptation with synchronization in progress
Red steady light	Fault <sup>1)</sup>
Red flashing light	After power interruption (> 2 s). The valve is automatically synchronized at the selected closing point the next time it closes. The LED indicator changes from a red flashing light to a green steady light.
Alternating red / green flashing light	Addressing via the control system and operation of the adaptation pushbutton S2 in progress

The actuator is maintenance-free. The twin-color LED indicator shows the actual actuator status.

It also allows simple commissioning if the factory settings need to be changed.

<sup>1)</sup> Possible causes: Actuator installed incorrectly; valve stem blocked; no valve installed. The adaptation must be repeated by pressing pushbutton S2 after all the above causes have been checked and rectified.

**Wiring diagrams of NV../AV.. multifunctional**

**Modulating (optional with feedback)**

Symbols		"Direct" signal	"Inverted" signal	Closing point "up"	Closing point "down"	Control signal min. (e.g. Y = 2 V)	Control signal max. (e.g. Y = 10 V)	Meas. signal min. (e.g. U = 2 V)	Meas. signal max. (e.g. U = 10 V)	Actuator spindle moves	
Direction of stroke	Valve closing point									S3.1	S3.2
H	Δ	OFF		OFF		x		x		RETRACTING	EXTENDING
	∇	OFF			ON	x		x		EXTENDING	RETRACTING
H	Δ		ON <sup>1)</sup>	OFF		x			x	RETRACTING	EXTENDING
	∇		ON <sup>1)</sup>		ON		x			EXTENDING	RETRACTING

1) If the controller generates a negative signal (< 0.15 V), slide switch S3.1 must not be set to "ON" if the operating range of the actuator is set to 2...10 V (exception: start point in the parameterized operating range = 0.5 V).

The control signal can be inverted by adjusting slide switch S3.1 to the "ON" position, and the valve closes as the control signal increases. This is a simple way of matching the sequences in the actuator. The closing point is down with fewer than 20% of the valves that are used and slide switch S3.2 must be set to the "ON" position. The position feedback U5 is likewise matched to the closing point.

**MFT actuator parameterized with 3-point control (optional with feedback)**

Symbols		"Direct" signal	"Inverted" signal	Closing point "up"	Closing point "down"	Relay contact a (Y1)	Relay contact b (Y2)	Meas. signal min. (e.g. U = 2 V)	Meas. signal max. (e.g. U = 10 V)	Actuator spindle moves	
"3-point" stroke direction	Valve closing point									S3.1	S3.2
H+ H- y2 y1	Δ	OFF		OFF		1	0	m		RETRACTING	EXTENDING
	∇	OFF			ON	0	1	m		RETRACTING	EXTENDING
H+ H- y2 y1	Δ		ON	OFF		1	0	m		RETRACTING	EXTENDING
	∇		ON		ON	0	1	m		RETRACTING	EXTENDING

\*) Measuring signal U5 according to position  
m: If relay contact a or b is in switch position 1 for longer than the running time (150 s)

The NV..-MFT.. linear actuator with MFT can also be used for 3-point control. The actuator must, however, be parameterized for 3-point control and provided with a 4-wire connection. **Note:** Only works with a nominal voltage of **AC 24 V!**

**Override control 100% (optional with feedback)**

Symbols		"Direct" signal	"Inverted" signal	Closing point "up"	Closing point "down"	Relay contact c	Relay contact d	Meas. signal min. (e.g. U = 2 V)	Meas. signal max. (e.g. U = 10 V)	Actuator spindle moves	
"Override" stroke direction	Valve closing point									S3.1	S3.2
H	Δ	OFF		OFF		1	0		x	RETRACTING	EXTENDING
	∇	OFF			ON	1	0		x	RETRACTING	EXTENDING
H	Δ		ON			1	0	x		EXTENDING	RETRACTING
	∇		ON		ON	1	0	x		EXTENDING	RETRACTING

A typical use for "100%" override control is in a frost protection circuit. Whether or not the frost thermostat has to interrupt the signal conductor to the controller "d" depends on the make of controller being used (not necessary if the signal output at the controller is short-circuit-proof and protected against polarity reversal).