

Damper actuator for operating air control dampers in ventilation and air-conditioning systems for building services installations

- For air control dampers up to approx. 8 m²
- Torque 40 Nm
- Nominal voltage AC/DC 24 V
- Control: Open-close (not made for 3-point applications)

Technical data

| | | |
|----------------------------|---------------------------|---|
| Electrical data | Nominal voltage | AC 24 V, 50/60 Hz DC 24 V |
| | Nominal voltage range | AC/DC 19.2 ... 28.8 V |
| | Power consumption | In operation 4.5 W @ nominal torque At rest 2 W For wire sizing 7 VA |
| | Connection | Cable 1 m, 3 x 0.75 mm ² |
| Functional data | Torque (nominal torque) | Min. 40 Nm @ nominal voltage |
| | Direction of rotation | Reversible with switch 0 ↺ or 1 ↻ |
| | Manual override | Gearing latch disengaged with pushbutton, self-resetting |
| | Angle of rotation | Max. 95°↔, limited on both sides by means of adjustable, mechanical end stops |
| | Running time | 150 s |
| | Sound power level | Max. 45 dB (A) |
| | Position indication | Mechanical, pluggable |
| Safety | Protection class | III Safety extra-low voltage |
| | Degree of protection | IP54 in any mounting position |
| | EMC | CE according to 89/336/EEC |
| | Mode of operation | Type 1 (to EN 60730-1) |
| | Rated impulse voltage | 0.8 kV (to EN 60730-1) |
| | Control pollution degree | 3 (to EN 60730-1) |
| | Ambient temperature range | -30 ... +50 °C |
| | Non-operating temperature | -40 ... +80 °C |
| | Ambient humidity range | 95% r.H., non-condensating (EN 60730-1) |
| | Maintenance | Maintenance-free |
| Dimensions / Weight | Dimensions | See «Dimensions» on page 2 |
| | Weight | Approx. 1'700 g |

Safety notes

- The damper actuator is not allowed to be used outside the specified field of application, especially in aircraft or any other form of air transport.
- Assembly must be carried out by trained personnel. Any legal regulations or regulations issued by authorities must be observed during assembly.
- The device may only be opened at the manufacturer's site. It does not contain any parts that can be replaced or repaired by the user.
- The cable must not be removed from the device.
- When calculating the required torque, the specifications supplied by the damper manufacturers (cross section, design, installation site), and the air flow conditions must be observed.
- The device contains electrical and electronic components and is not allowed to be disposed of as household refuse. All locally valid regulations and requirements must be observed.

Product features

- Simple direct mounting** Simple direct mounting on the damper spindle with a universal spindle clamp, supplied with an anti-rotation strap to prevent the actuator from rotating.
- Manual override** Manual operation is possible with the self-resetting pushbutton (the gearing latch remains disengaged as long as the pushbutton is pressed).
- Adjustable angle of rotation** Adjustable angle of rotation with mechanical end stops.
- High functional reliability** The actuator is overload-proof, requires no limit switches and automatically stops when the end stop is reached.

Accessories

| | Description | Data sheet |
|------------------------|-------------------------------------|-------------|
| Electrical accessories | Auxiliary switch, type S..A.. | T2 - S..A.. |
| | Feedback potentiometer, type P..A.. | T2 - P..A.. |

Electrical installation

Wiring diagrams

Notes

- Connection via safety isolating transformer. 
- Other actuators can be connected in parallel. Please note the performance data.

Direction of rotation

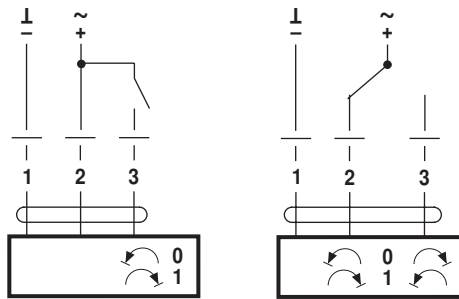

Dimensions [mm]

Dimensional drawings

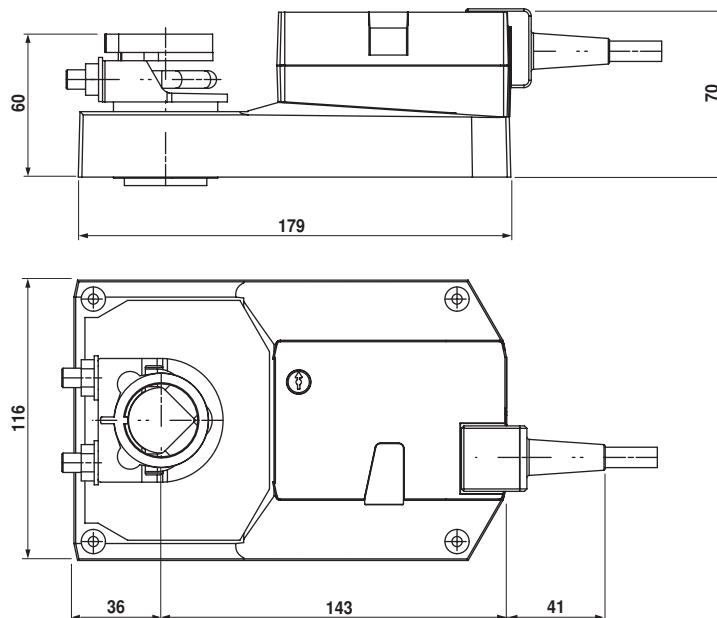

| Damper spindle | Length |  |
|-----------------|---------|---|
| Clamp on top | min. 51 | 14 ... 26 |
| Clamp on bottom | min. 20 | 14 ... 26 |

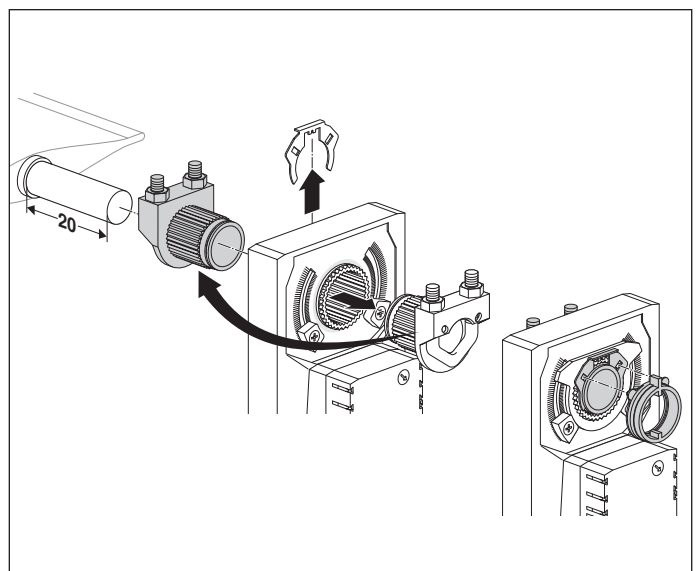
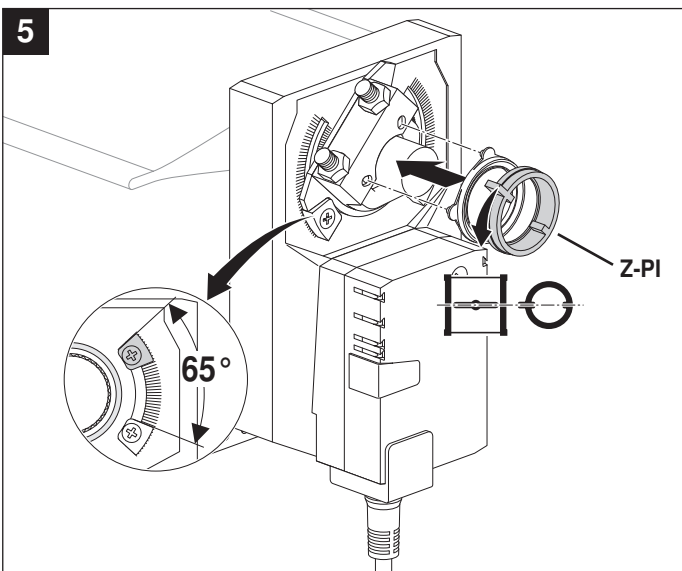
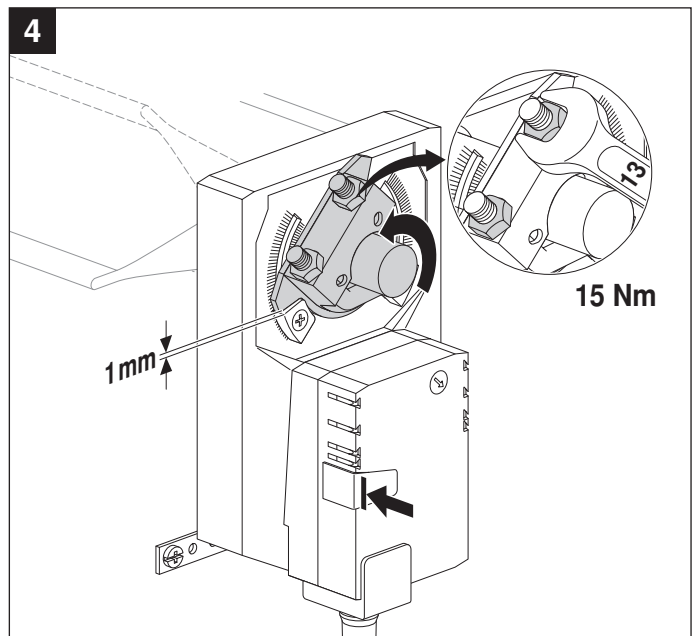
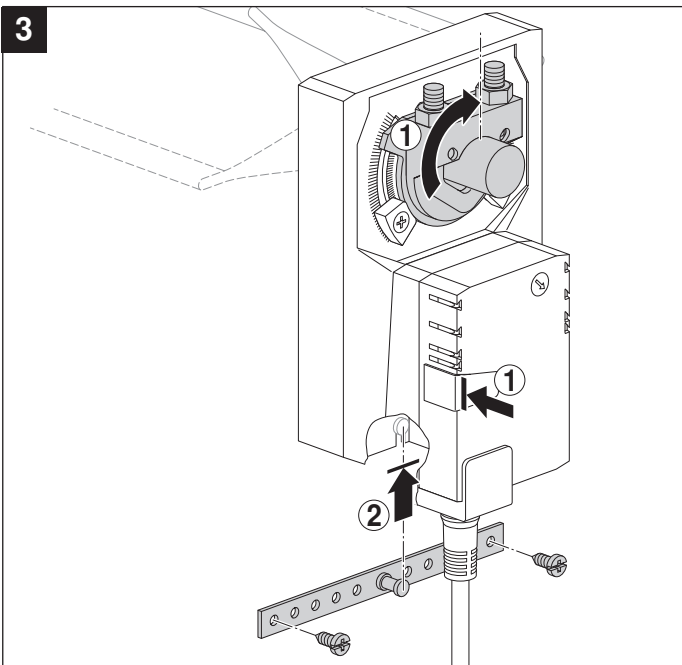
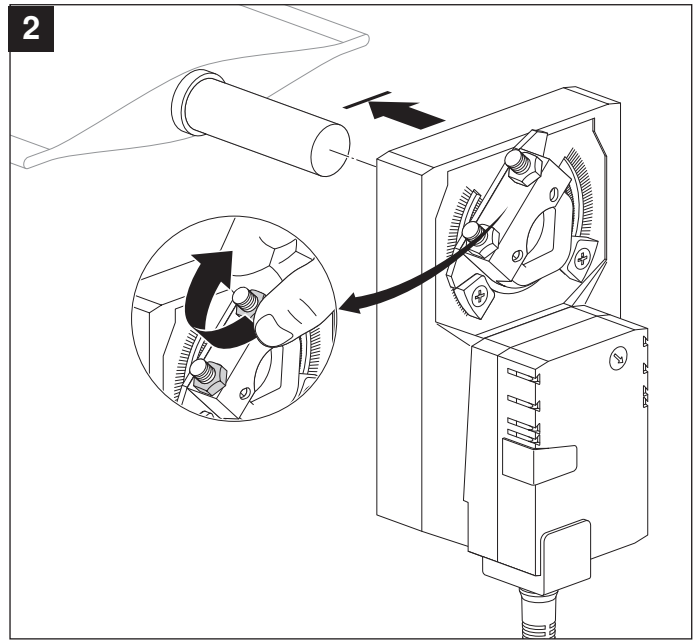
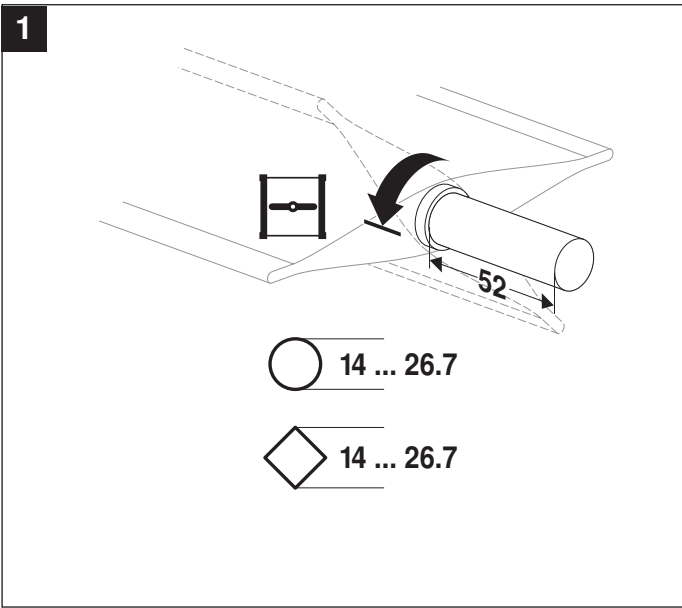

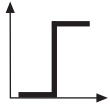
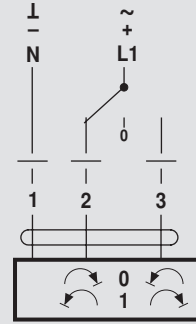
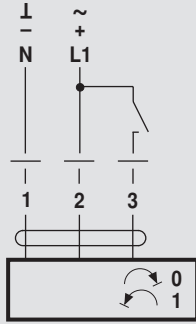

AC 24 V / DC 24 V

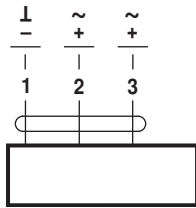

GM24A..

AC 100 ... 240 V ⚠

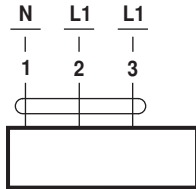

GM230A..

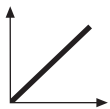

AC 24 V / DC 24 V

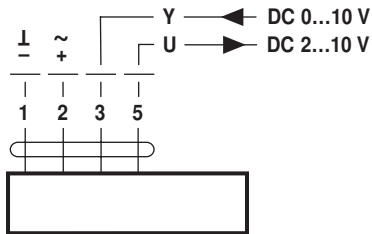

GM24A-SR..
GM24A-MF..

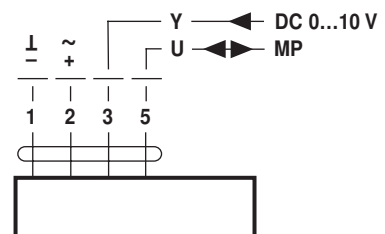

GM24A-MP..