

Damper actuator for operating air control dampers in ventilation and air-conditioning systems for building services installations

- For air control dampers up to approx. 2 m<sup>2</sup>
- Torque 10 Nm
- Nominal voltage AC/DC 24 V
- Control: modulating DC 0 ... 10 V, position feedback DC 2 ... 10 V

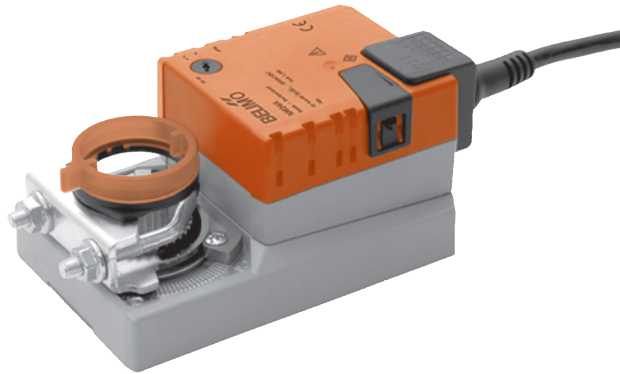

### Technische Daten

Electrical data	Nominal voltage	AC 24 V, 50/60 Hz DC 24 V
	Nominal voltage range	AC/DC 19.2 ... 28.8 V
	Power consumption	In operation 2 W @ nominal torque At rest 0.4 W For wire sizing 4 VA
	Connection	Cable 1 m, 4 x 0.75 mm <sup>2</sup>
Functional data	Torque (nominal torque)	Min. 10 Nm @ nominal voltage
	Control	Control signal Y DC 0 ... 10 V, typical input impedance 100 kΩ Working range DC 2 ... 10 V
	Position feedback (Measuring voltage)	DC 2 ... 10 V, max. 1 mA
	Position accuracy	±5%
	Direction of rotation	Reversible with switch 0 / 1
	Direction of rotation at Y = 0 V	at switch position 0 ↺ resp. 1 ↻
	Manual override	Gearing latch disengaged with pushbutton, self-resetting
	Angle of rotation	Max. 95°↔, limited on both sides by means of adjustable, mechanical end stops
	Running time	150 s
	Sound power level	Max. 35 dB (A)
Safety	Position indication	Mechanical, pluggable
	Protection class	III Safety extra-low voltage
	Degree of protection	IP54 in any mounting position
	EMC	CE according to 89/336/EEC
	Mode of operation	Type 1 (to EN 60730-1)
	Ambient temperature range	-30 ... +50 °C
	Non-operating temperature	-40 ... +80 °C
	Ambient humidity range	95% r.H., non-condensating (EN 60730-1)
	Maintenance	Maintenance-free
	Dimensions / Weight	Dimensions
Weight		Approx. 800 g

### Safety notes



- The damper actuator is not allowed to be used outside the specified field of application, especially in aircraft or any other form of air transport.
- Assembly must be carried out by trained personnel. Any legal regulations or regulations issued by authorities must be observed during assembly.
- The device may only be opened at the manufacturer's site. It does not contain any parts that can be replaced or repaired by the user.
- The cable must not be removed from the device.
- When calculating the required torque, the specifications supplied by the damper manufacturers (cross section, design, installation site), and the air flow conditions must be observed.
- It is not permissible to use a screw instead of the anti-rotation strap.
- The device contains electrical and electronic components and is not allowed to be disposed of as household refuse. All locally valid regulations and requirements must be observed.

**Product features**

<b>Mode of operation</b>	The actuator is controlled by means of a standard control signal DC 0 ... 10 V. It opens to the position dictated by this signal. The measuring voltage U allows the damper position (0 ... 100%) to be electrically indicated and serves as a follow-up control signal for other actuators.
<b>Simple direct mounting</b>	Simple direct mounting on the damper spindle with a universal spindle clamp, supplied with an anti-rotation strap to prevent the actuator from rotating. It is not permissible to use a screw instead of the anti-rotation strap.
<b>Manual override</b>	Manual operation is possible with the self-resetting pushbutton (the gearing latch remains disengaged as long as the pushbutton is pressed).
<b>Adjustable angle of rotation</b>	Adjustable angle of rotation with mechanical end stops.
<b>High functional reliability</b>	The actuator is overload-proof, requires no limit switches and automatically stops when the end stop is reached.

**Accessories**

	Description	Data sheet
<b>Electrical accessories</b>	Auxiliary switch S..A..	T2 - S..A..
	Feedback potentiometer P..A..	T2 - P..A..
	Range controller SBG24	T2 - SBG24
	Positioner SG..24	T2 - SG..24
	Digital position indication ZAD24	T2 - ZAD24
<b>Mechanical accessories</b>	Various accessories (clamps, shaft extensions etc.)	T2 - Z-NM..A..

**Electrical installation**

**Wiring diagrams**

**Notes**

- Connection via safety isolating transformer.
- Other actuators can be connected in parallel. Please note the performance data.

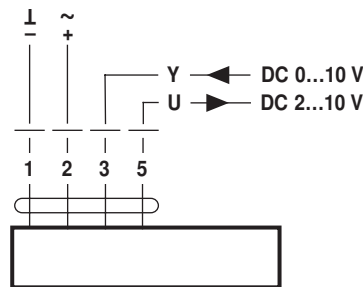

**Dimensions [mm]**

**Dimensional drawings**

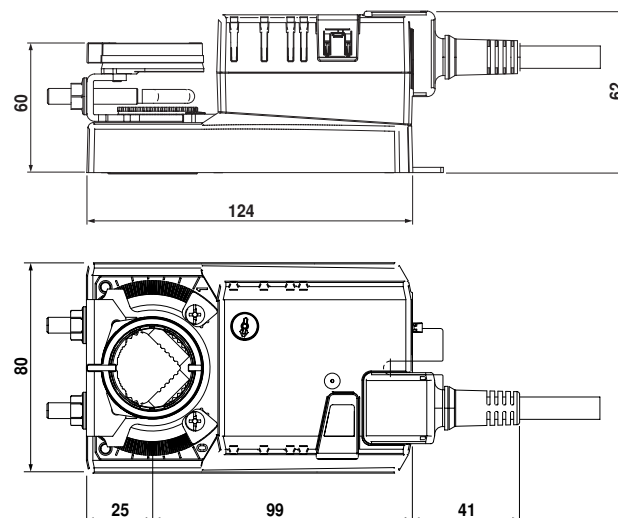

Damper spindle	Length	
Clamp on top	min. 40	8 ... 26.7
Clamp on bottom *	min. 20	8 ... 20

\* Option (Accessory K-NA)

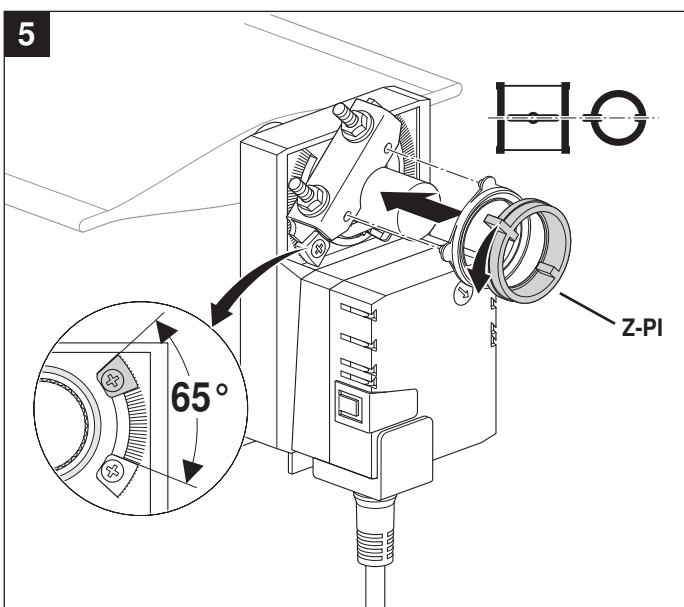
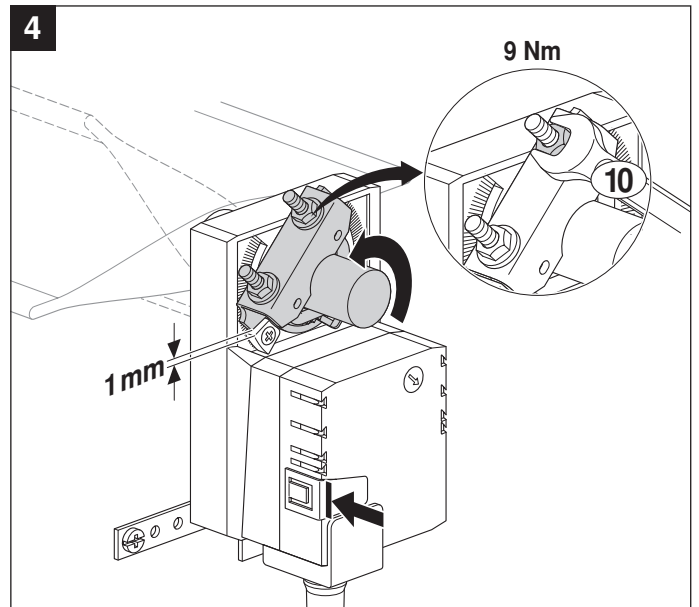
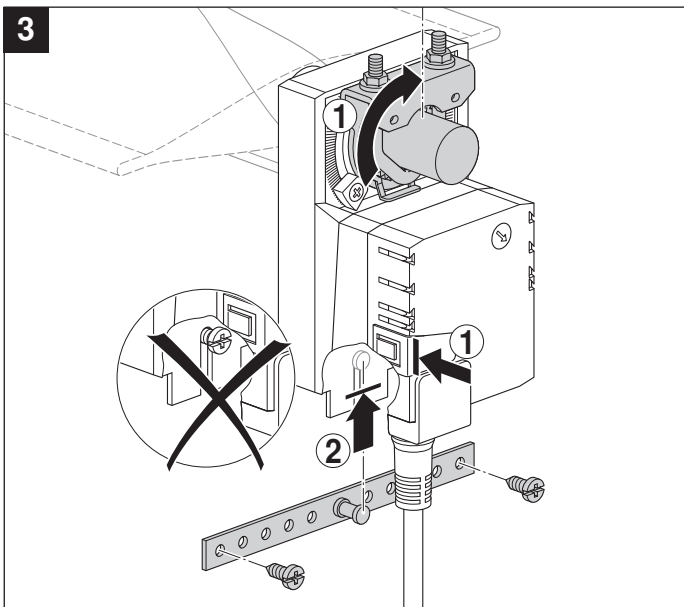
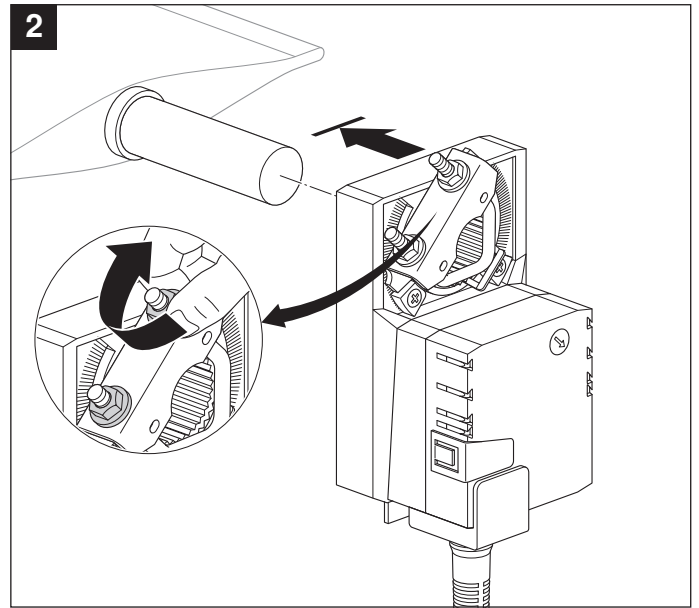
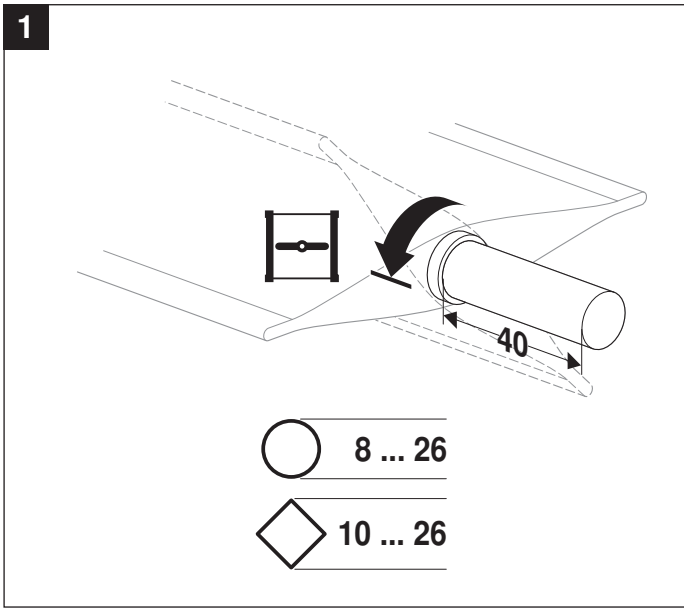

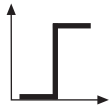
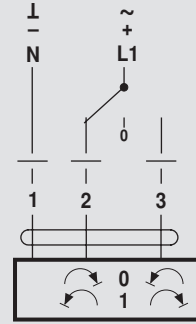
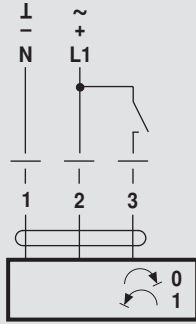

AC 24 V / DC 24 V

DC 48 ... 110 V  
(NM72A..)

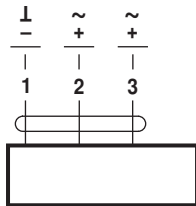

NM24A..  
NM72A..

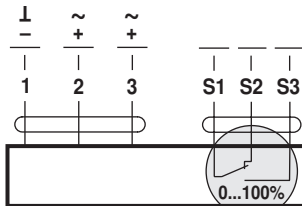

NM24A-S..

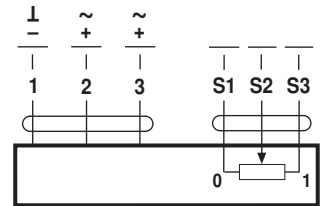

NM24AP5..

AC 100 ... 240 V

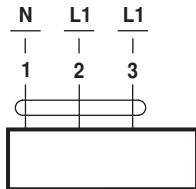

NM230A..

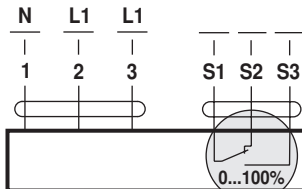

NM230A-S..

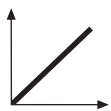
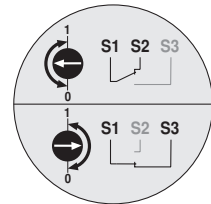

AC 24 V / DC 24 V

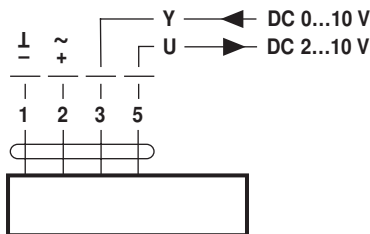

NM24A-SR..  
NM24A-MF..

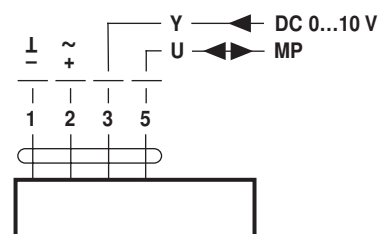

NM24A-MP..

DC 48 ... 110 V  
(NM72A-SR..)

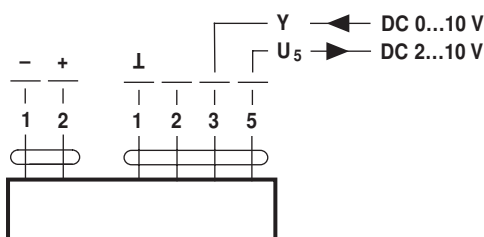

NM72A-SR..

AC 100 ... 240 V

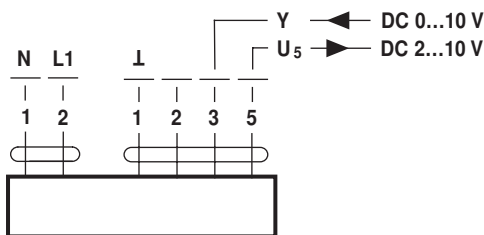

NM230ASR..