

Positioner, suitable for modulating damper actuators LM..A-SR, NM..A-SR, SM..A-SR and GM..A-SR

- For flush mounting

Technical data

Electrical data	Nominal voltage	AC 24 V, 50/60 Hz DC 24 V Vcc from ..M230ASR
	Nominal voltage range	AC/DC 19.2 ... 28.8 V
	Power consumption	0.3 W
	For wire sizing	1 VA
	Power output	For max. 10 actuators
	Connection	Terminals (for max. 1.5 mm ²)
	Functional data	Control signal Y
Scale		0 ... 100% (mechanical rotation limit by knob)
Safety		Protection class
	Degree of protection	IP40 (IP54 with conduit connector)
	EMC	CE according to 89/336/EWG
	Mode of operation	Type 1.B (to EN 60730-1)
	Ambient temperature range	-20 ... +50 °C
	Non-operating temperature	-40 ... +80 °C
	Humidity test	To EN 60730-1
Maintenance	Maintenance free	
Dimensions / Weight	Dimensions	See «Dimensions» on page 2
	Weight	Approx. 50 g

Safety notes

- The positioner is not allowed to be used outside the specified field of application, especially not in aircraft or any other form of air transport.
- Assembly must be carried out by trained personnel. Any legal regulations or regulations issued by authorities must be observed during assembly.
- The device may only be opened at the manufacturer's site. It does not contain any parts that can be replaced or repaired by the user.
- The device contains electrical and electronic components and is not allowed to be disposed of as household refuse. All locally valid regulations and requirements must be observed.

Product features

Application	The positioner is intended for the remote control of modulating actuators or for use as a minimum positioner (providing a bottom limit for the output signals from modulating controllers). The control range is 0 ... 100% of the angle of rotation of the actuator.
Wide setting range	The positioner receives its power supply through terminals 1 and 2. The position to which the rotary knob is turned produces a proportional control signal Y of either DC 2 ... 10 V or DC 0 ... 10 V and thus a proportional change in the position of the actuator between 0 and 100%. The angle of rotation of the knob can be limited mechanically.
Simple changeover	The changeover from DC 2 ... 10 V to DC 0 ... 10 V is selected by means of a slide switch on the printed circuit board.

Electrical installation

Wiring diagram

Note

Connection via safety isolating transformer.

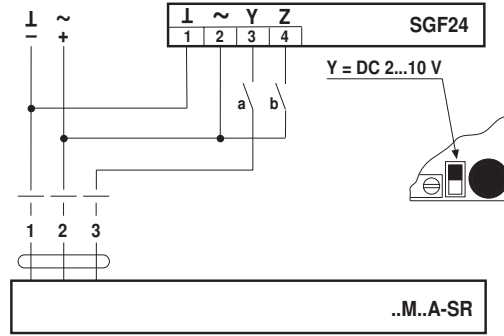

a	b	Y
		0 %
		0 %
		0...100 %
		100 %

Dimensions [mm]

Dimensional drawings

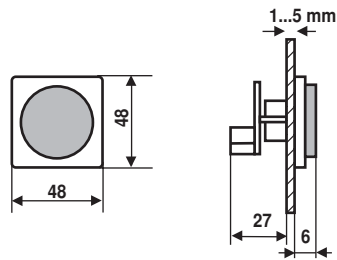

Drilling template

