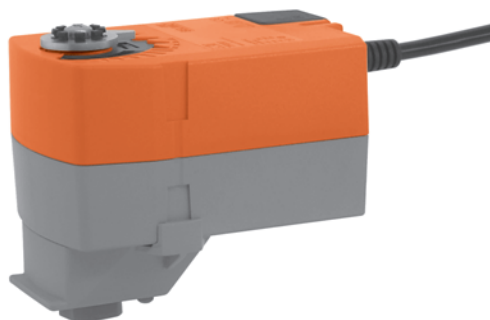

Open-close rotary actuator with emergency control function for 2- and 3-way ball valves

- Torque 1.6 Nm
- Nominal voltage AC/DC 24 V
- Control: Open-close

Overview of types

Type	Direction of rotation
TRFD24	Deenergised NC, ball valve closed (A – AB = 0%)
TRFD24-O	Deenergised NO, ball valve open (A – AB = 100%)

Technical data

Electrical data	Nominal voltage	AC 24 V, 50/60 Hz DC 24 V	
	Nominal voltage range	AC 19.2 ... 28.8 V DC 21.6 ... 28.8 V	
	Power consumption	Spring-return 2.5 W @ nominal torque Holding position 1.5 W For wire sizing 5 VA	
	Connection	Cable 1 m, 2 x 0.75 mm ²	
	Parallel connection	Yes (note performance data for supply!)	
Functional data	Torque (nominal torque)	Motor Min. 1.6 Nm @ nominal voltage Spring-return Min. 1.6 Nm	
	Direction of rotation	see «Overview of types»	
	Manual override	No	
	Angle of rotation	Max. 95°↯	
	Running time	Motor <75 s (0 ... 2 Nm) Spring-return 75 s	
	Sound power level	Motor Max. 50 dB (A) Spring-return ~43 dB (A)	
	Service life	Min. 60'000 emergency settings	
	Position indication	Mechanical	
	Safety	Protection class	III Safety extra-low voltage
		Degree of protection	IP42 in any mounting position
EMC		CE according to 2004/108/EC	
Mode of operation		Type 1 (EN 60730-1)	
Rated impulse voltage		0.8 kV (EN 60730-1)	
Control pollution degree		3 (EN 60730-1)	
Ambient temperature		-30 ... +50 °C	
Media temperature		+5 ... +100 °C (in ball valve)	
Non-operating temperature		-40 ... +80 °C	
Ambient humidity		95% r.H., non-condensating (EN 60730-1)	
Maintenance	Maintenance-free		
Dimensions / Weight	Dimensions	See «Dimensions» on page 2	
	Weight	Approx. 600 g (without ball valve)	

Safety notes

- The actuator has been designed for use in stationary heating, ventilation and air conditioning systems and is not allowed to be used outside the specified field of application, especially in aircraft or in any other airborne means of transport.
- It may only be installed by suitably trained personnel. Any legal regulations or regulations issued by authorities must be observed during assembly.
- The device may only be opened at the manufacturer's site. It does not contain any parts that can be replaced or repaired by the user.
- The cable must not be removed from the device.
- The device contains electrical and electronic components and is not allowed to be disposed of as household refuse. All locally valid regulations and requirements must be observed.

Product features

Mode of operation	The actuator moves the ball valve to the operating position at the same time as tensioning the return spring. The ball valve is turned back to the safety position by spring force if the supply voltage is interrupted.
Simple direct mounting	Straightforward direct mounting on the ball valve with only one screw. The mounting position in relation to the ball valve can be selected in 90° steps.
High functional reliability	The actuator is overload-proof, requires no limit switches and automatically stops when the end stop is reached.
Combination valve/actuators	Refer to the valve documentation for suitable valves, their permitted media temperatures and closing pressures.

Electrical installation

Wiring diagram

Note

- Connect via safety isolation transformer.
 - Other actuators can be connected in parallel.
- Note performance data for supply.

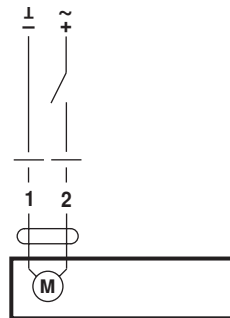

Dimensions [mm]

Dimensional drawings

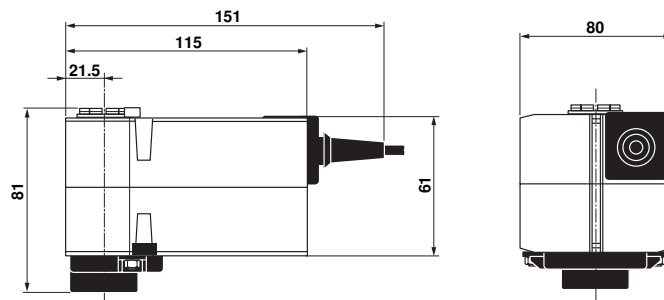

Further documentations

- Complete overview «The complete range of water solutions»
- Data sheets for ball valves
- Installation instructions for actuators resp. ball valves
- Notes for project planning (hydraulic characteristic curves and circuits, installation regulations, commissioning, maintenance etc.)

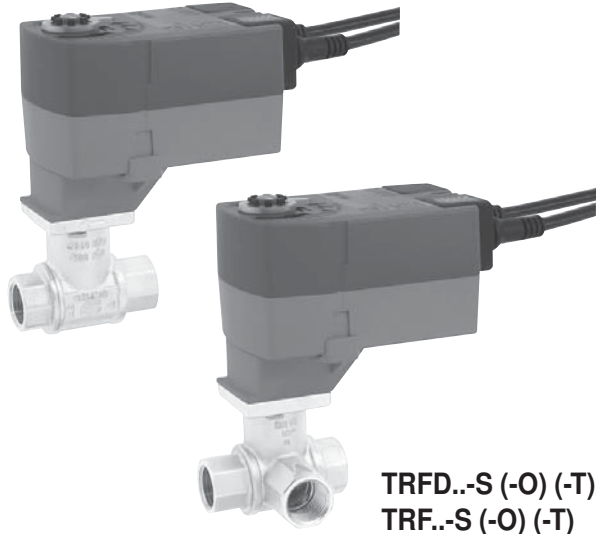



TRFD..S (-O) (-T)
TRF..S (-O) (-T)

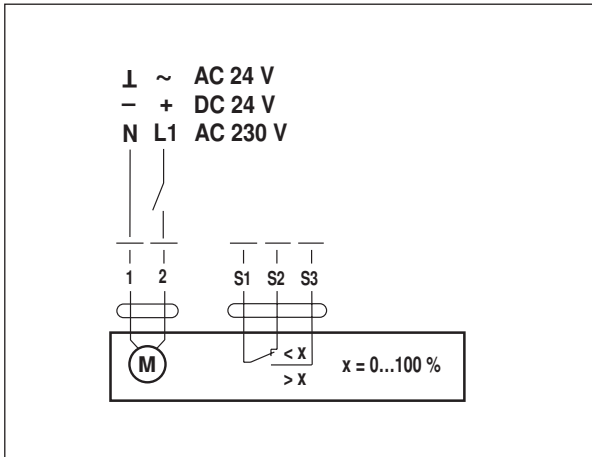
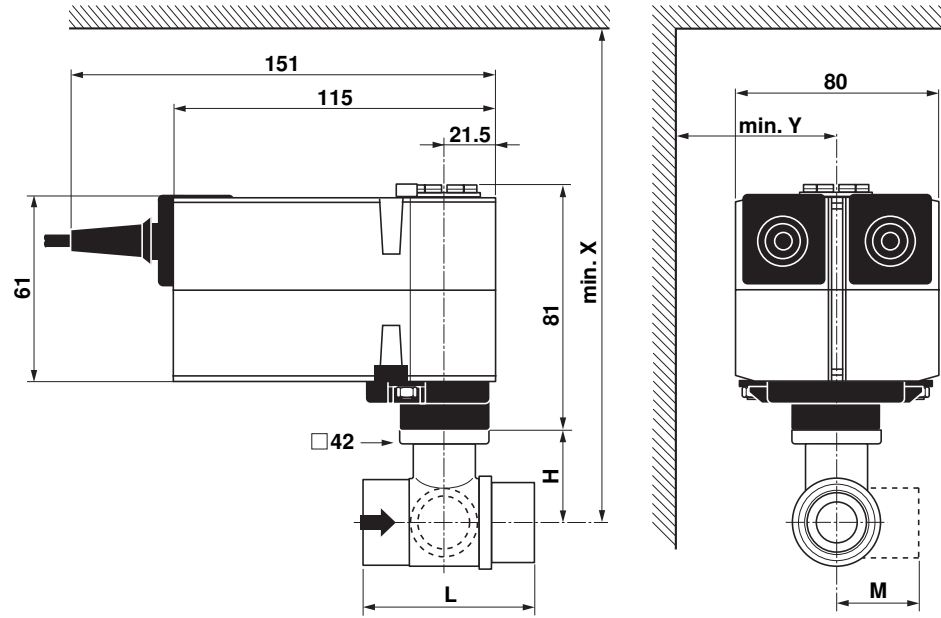

70330-00001.A



		DN		Rp	G	PN	mm							
		mm	"							TRFD..S(-O)(-T)		TRF..S(-O)(-T)		
							L	H	M	X	Y	X	Y	
R2..K	R3..K	10	3/8	3/8			52	35	28	180	80			
R4..K	R5..K	10	3/8		3/4		69	31.5	34	180	80			
R2..	R3..	15	1/2	1/2			67	45	39			190	80	
R4..	R5..	15	1/2		1		74	44	38			190	80	
R6..R	R7..R	15	1/2			6	101.5	45	73			190	80	

TRFD..-S(-T)
TRF..-S(-T)

TRFD..-S-O(-T)
TRF..-S-O(-T)

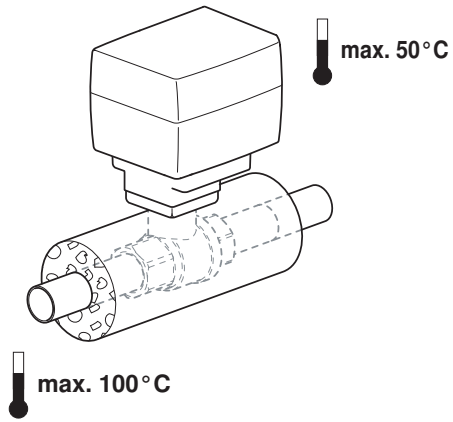
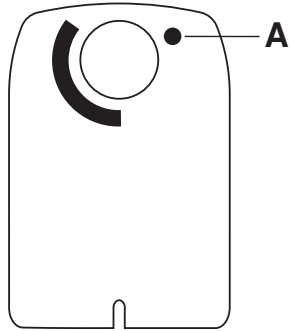
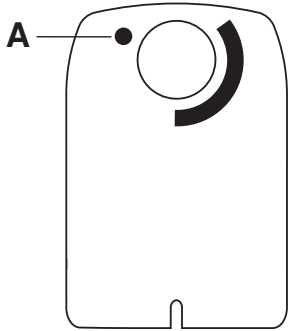

TRFD..-S(-T)
TRF..-S(-T)

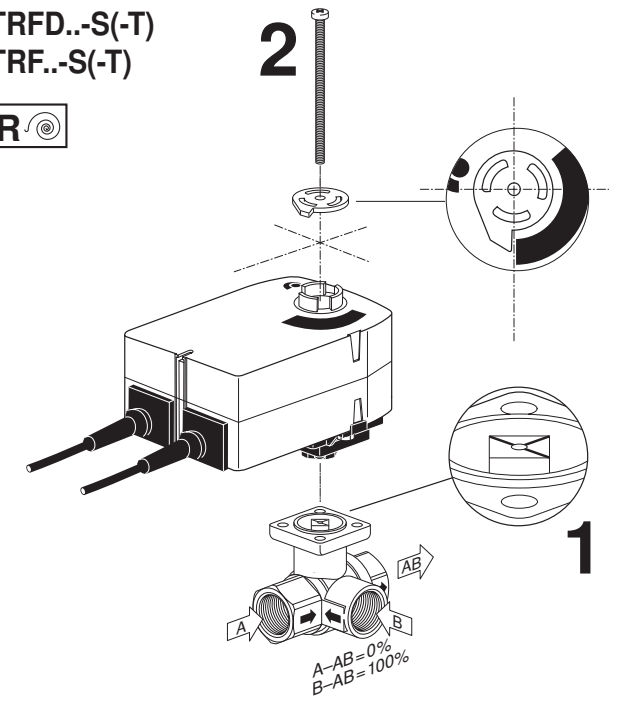

TRFD..-S(-T)
TRF..-S(-T)

TRFD..-S-O(-T)
TRF..-S-O(-T)

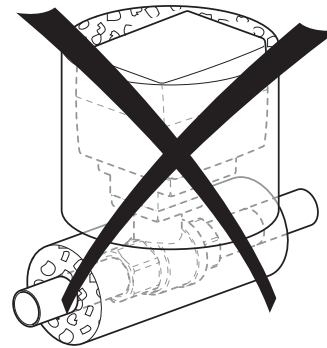

TRFD..-S-O(-T)
TRF..-S-O(-T)

