

# InCos-D Transducer for InPro sensors (probes) InPro-... Temperature-/humidity sensors (°C, % rH)

Electrical transducer only connectable for **InPro-...** temperature and humidity sensors.  
24 VAC/DC supply, 0...10 V / (0) 4...20 mA output

Type of transducer:  
**InCos - D**  
**InCos - D - A**  
 Type of sensor (probe):  
**InPro - CT...**  
**InPro - CF...**  
**InPro - CTF...**  
 Subject to change!

## Transducer

Type	supply	installation area	connectable sensors	function of sensors	sensor connection	wiring
<b>InCos - D</b>	24 VAC/DC	safe area	InPro-CT ..., InPro-CF..., InPro-CTF...	°C, %rH, combination °C/%rH	via plug - and - socket connection	SB 2.0
<b>InCos - D... - A</b>	as above,	but with additional analogue output to connect an external digital indicator(0) 4...20 mA				SB 3.0

## Connectable sensors (compulsory for InCos-... transducer) – have a look onseparate data sheet

Type	function	measuring range	length of sensor	connectable to	installation sensor	installation transducer
<b>InPro - CT...</b>	temperature	-40...+125 °C	50/100/150/200 mm	InCos-D...	secure area	secure area
<b>InPro - CF...</b>	humidity	0...100 % rH	50/100/150/200 mm	InCos-D...	secure area	secure area
<b>InPro - CTF...</b>	combination temp./humidity	-40...+125 °C/0...100 % rH	50/100/150/200 mm	InCos-D...	secure area	secure area

## Applicaton

### InCos-D... transducer



### InPro... sensor



### Example: room sensor



### Example: duct sensor



## Description

The new **InCos-D...** transducer generation from together with direct coupled **InPro sensors** are a revolution for measuring temperature and/or humidity in HVAC systems, in chemical, pharmaceutical, industrial and Offshore-/Onshore plants.

IP 66 protection, small dimension, universal functions and technical data guarantee safe operation even under difficult environmental conditions.

The measuring ranges are scalable within the maximum ranges. The analogue output signal is either 0...10 VDC or 4...20 mA and can be selected on site. The integrated display is for actual value indication which can be switched off.

All sensors are programmable on site without any additional tools.

**InCos-D-A** transducer are additionally equipped with a 4...20 mA output, e.g. for an external indicator.

## Highlights transducer

- ▶ Industrial sensor
- ▶ Integrated junction box
- ▶ Power supply 24 VAC/DC
- ▶ Display with backlight, can be switched off
- ▶ Scalable analogue output, selectable 0...10 V / (0) 4...20 mA
- ▶ Compact design and small dimension (L x W x H = 177 x 107 x 66 mm)
- ▶ Robust aluminium housing in protection class IP 66
- ▶ Down to -20°C ambient temperature applicable
- ▶ Password locking
- ▶ Optional output (4...20 mA) for external indicator

## Highlights sensor

- ▶ Plug-and-socket connection to InCos-D... transducer, removable
- ▶ The InPro probe appropriates the function (temperature, humidity or combination)
- ▶ Mounting of InPro probe (front/back side) appropriates use for duct or room application

Technical data	InCos-D...
Power supply	24 VAC/DC +/- 20% (19,2 ... 28,8 VAC/DC) 50...60 Hz
Current, power consumption	150 mA, ~ 4 W, internal fuse 500 mA, without bracket, not removable
Galvanic isolation	supply - analogue output 1,5 kV
Electrical connection	terminals 0,14 ... 2,5 mm <sup>2</sup> at integrated junction box
Cable entry	M16x1,5 cable diameter ~ Ø 5...10 mm
Protection class	Class I (grounded)
Display	2 x 16 digits, dot-matrix with backlight, display for configuration, user guidance, parameter and actual value indication
Control elements	3 buttons for configuration
Housing protection	IP66 in acc. to IEC 60529
Housing material	aluminium casting, coated
Dimensions / weight	L x W x H = 177 x 107 x 66 mm / ca. 950 g
Ambient temperature/-humidity	- 20 ... + 50 °C / 0 ... 95 % rH, non condensed
Storage temperature	- 40 ... + 70 °C
Sensor connection	<b>only for InPro-... sensors!</b> via plug-and-socket connection at front or back side of the transducer, to appropriate the use for room or duct mounting. <b>Attention:</b> only one InPro-probe can be connected to one transducer!
InPro sensors	please have a look on the separate data sheet for InPro-... sensors
Measuring range	measuring ranges are scalable within the maximum measuring range
Maintenance	maintenance free, nevertheless maintenance must be complied with regional standards, rules and regulations
Response time of sensor	T90 ~ 1 sec.
Accuracy temperature	± 0,2 % of end value + accuracy of InPro-... sensor ± 0,3 °C at 25 °C ± 0,025 °C/°C
Accuracy humidity	± 0,2 % of end value + accuracy of InPro-... sensor 10 ... 90 %rH ± 2% and < 10%rH and > 90%rH ± 4%
Non linearity and hysteresis	± 0,1 % (± 0,1 % of end value + accuracy of InPro-... sensor)
Start delay	5 sec.
Stability	long term stability < 0,2 % / year, temperature influence < 0,02 %/K, supply voltage influence < 0,01 %
Output	voltage U(V) or current I(mA) selectable via menu on site
Output protection	against short circuit and external voltage up to 24 V, protected against polarity reversal
Voltage output U	from 0...10 VDC adjustable, invertible, burden > 1 kΩ, influence < 0,05% / 100 Ω
Current output I	from 0...20 mA adjustable, invertible, burden < 500 Ω, influence < 0,1% / 100 Ω, open circuit voltage < 24 V
Output at alarm mode	increasing or decreasing output signal, selectable on site, down to 0 VDC/0 mA or up to 10 VDC/20 mA
Wiring diagram (SB)	SB 2.0
Delivery (changeable on site)	output 4 ... 20 mA, output with decreasing alarm situation to 0V/0mA
Included in delivery	InCos-D... with 3 screws 4,2x13 self-tapping
Installation area transducer	in safe area

**Additional information for InCos-D...-A:**

Analogue output	(0) 4...20 mA
Burden	max. 400 Ω
Accuracy	± 0,5 %
Plug	cable diameter Ø 6...8 mm
Delivery version ...-D-A	incl. 2 x plug

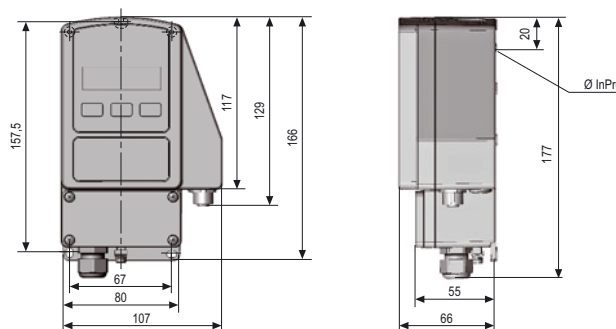
**Dimensions / Drillings**

Certification	InCos-D...
Identification	CE
EMC	89/336/EC EMC directive
Low voltage	73/23/EC low voltage directive
Protection type	IP 66 in acc. to EN 60529
Potential compensation	external PA-terminal, 4 mm <sup>2</sup>

Accessories	
<b>NOC-RIA-261</b>	LCD indicator, installation in safe area connectable direct to InCos-... sensors with type InCos-P.- A
<b>MKR</b>	Mounting bracket for round ducts up to Ø 600 mm
<b>MFK</b>	Mounting flange for probe positioning

**Electrical wiring**

InCos-D... transducer required a 24 VAC/DC power supply. The supply has to be connected at terminal 1 (-/~) and 2 (+/~), the analogue output at terminal 3 (mA/V) and 4 (GND) for temperature, at terminal 5 (mA/V) and 4 (GND) for humidity.

**Parameter**

Before starting parametrisation of InCos-D... transducer an InPro-... sensor must be connected. InPro-... sensors are available as InPro-CT...for single temperature measurement, as InPro-CF... for single humidity measurement and as InPro-CTF... for combined measurement of temperature and humidity. All types are connectable to an InCos transducer but only one sensor to one transducer. In acc. with the sensor type you need to set parameter for one or two measuring ranges.

**Wiring diagram InCos-D...**

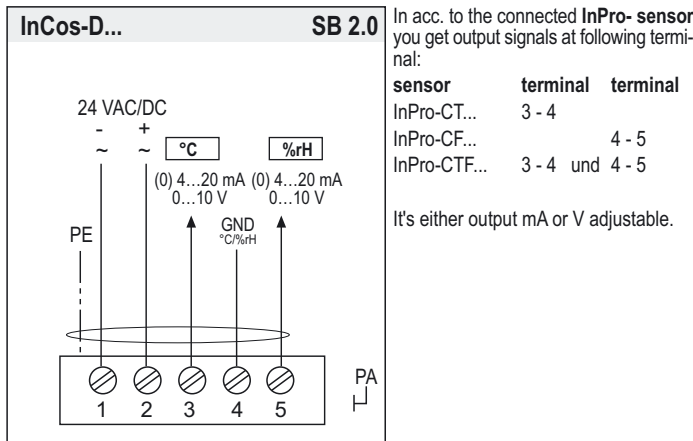

**Display and Buttons**

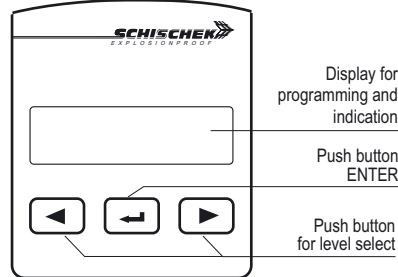

**Change operation- / parametrisation mode**

To change from operation to parametrisation mode and vice versa, push the enter button for minimum 3 seconds.

**Indication of data logging**

A blinking star in the display shows that datas received and the device is working.

**Wiring of output (optional) at InCos-D-A transducer**

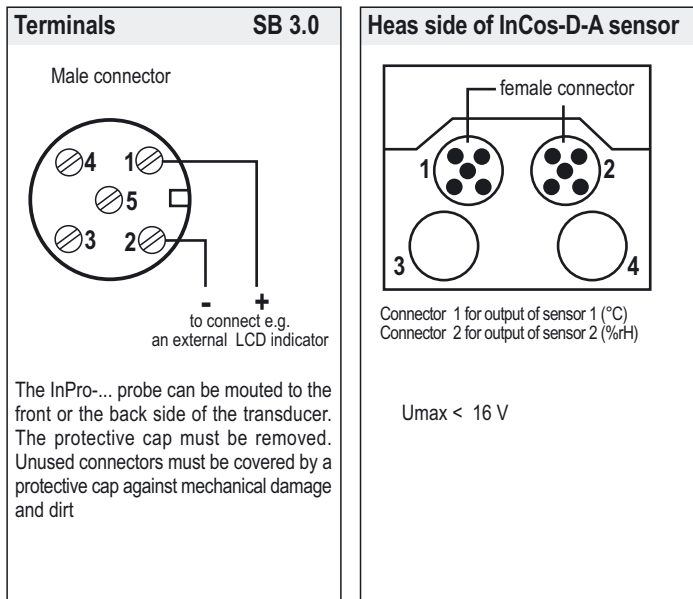

**Password input**

The default / delievery setup is 0000. In this configuration the password input is not activated. To activate a password, go to menu point 20, change the 4 digits into your choosen numbers (e.g. 1234) and press Enter.

**Please keep your password in mind for next parameter change!**

Due to a new parameter setup the password is requested.

**Important information for installation and operation**

**A. Installation, Commisioning, Maintenance**

The cable has to be drawn through the cable gland. After electrical connection the cable gland must be fixed tighten. IP66 must be fulfilled.

In acc. with operation InCos sensors are maintenance free. Nevertheless maintenace must comply with regional standards, rules and regulations.

The sensors must not be opened by the customer. For outdoor installation a protective housing against rain, snow and sun should be applied. For electrical connection use the internal junction box.

**B. InPro sensors**

InPro sensors are supplied with an intrinsic safe circuit from the InCos-D.. transducer. Unused connectors must be covered by a protective cap.

**C. Long cabling**

For using long signal wires, shielded cables are recommended. The shield must be connected to the InCos-D transducer inside the terminal box.

**D. Separate ground wires**

Use for supply and signal wires a separate ground.



**Values for InPro sensors**

**Digital InPro sensor**

$U_{max} < 5,5 V$

Parametrisation and commissioning of InCos-D (-A) transducers after an InPro sensor ist connected

Preparation of parametrisation/operation

Operation ↔ Parametrisation, push  for 3 sec.  
If password (PW) protection is active: put PW in, push 



































































































































Change operation- / parametrisation mode

To change from operation to parametrisation mode push "enter button"  for minimum 3 seconds. Back over the menu save and exit.

Example of parameters

Language english  
Range 0...+50 °C, 0...100%rH  
Output each 0...10 VDC, 0...20 mA  
add Outputs 4...20 mA

Menu	Function	Enter	Indication	Select	Enter	Next indication	Next selction	Enter	Next menu
Menu 1	DE, EN, FR select language: german, english, frensh		DE, EN, FR english	 					
Menu 2	no function - menu skip		deutsch, english, francais						
Menu 3	no function - menu skip								
Menu 4	unit sensor 1 select physical unit		unit sensor 1 °C	 					
Menu 5	range 1 adjust the measuring range		range 1 0..50 °C	 		range 1 0..50 °C	 		
Menu 6	no function - menu skip		↑ adjust lower limit			↑ adjust higher limit			
Menu 7	output V, mA select output signal as VDC or mA		output V/mA V	 					
Menu 8	output range 1 adjust the output range		output range 1 0..10V	 		output range 1 0..10V	 		
Menu 9	sensor error 1 select signal at sensor error		sensor error 1 10V / 20 mA	 					
Menu 10	output 1   select if signal output is increasing or decreasing		output 1   increasing	 		  increasing, decreasing			
Menu 11	unit sensor 2* select physical unit		unit sensor 2 %rH	 					
Menu 12	range 2* adjust the measuring range		range 2 0..100 %rH	 		range 2 0..100 %rH	 		
Menu 13	output range 2* adjust the output range		output range 2 0..10V	 		output range 2 0..10V	 		
Menu 14	sensor error 2* select signal at sensor error		sensor error 2 0V / 0 mA	 					
Menu 15	output 2*   select if signal output is increasing or decreasing		output 2   increasing	 		  increasing, decreasing			
Menu 16	add output 1 (option, only at InCos-D-A) adjust 4...20 mA or 0...20 mA IS output signal		add output 1 4..20 mA	 		add output 1 4..20 mA	 		
Menu 17	add output 2 (option, only at InCos-D-A)* adjust 4...20 mA or 0...20 mA IS output signal		add output 2 4..20 mA	 		add output 2 4..20 mA	 		
Menu 18	no function - menu skip		↑ adjust lower limit			↑ adjust higher limit			
Menu 19	display function select display on/off, illuminated or backlight off		display function on illuminated	 		on-illuminated, on, off			
Menu 20	password select password protection		new password yes no	 		password 0000	 		
Menu 21	save and exit select save data / factory setting / discard or back to menu		save and exit save data	 					
Menu 22	Set offset 1 Add / subtract from measures value		set offset 1 0.00°C	 					
Menu 23	Set offset 2* Add / subtract from measures value		sett offset.2 0.00%rH	 					

\*only available if comibantion sensor type InPro-CTF... is connected

# InPro-... Digital Temperature-/Humidity Probe

Digital probe exclusive connectable to InCos-D transducer for temperature and/or humidity measuring

InPro - CT...  
InPro - CF...  
InPro - CTF...

Subject to change!

Type	Function	Range	Sensor length	Applicable to transducer	Installation area
InPro - CT...	Temperature Probe	-40...+125 °C	50/100/150/200 mm	InCos-D	safe area
InPro - CF...	Humidity Probe	0...100 %rF	50/100/150/200 mm	InCos-D	safe area
InPro - CTF...	Combi Probe	-40...+125 °C/0...100 %rF	50/100/150/200 mm	InCos-D	safe area

↑  
Sensor length

## Application

### InPro Sensors



### Application Room



### Application Duct

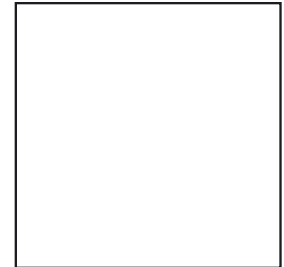
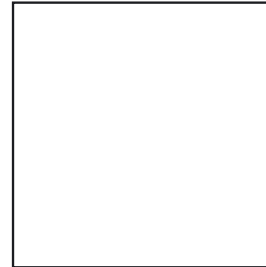

Technical data	InPro-CT...	InPro-CF...	InPro-CTF...
<b>Application for</b>	Temperature Probe	Humidity Probe	Combi Probe Temperature and Humidity
<b>Measuring Range</b>	-40 °C...+ 125 °C	0...100 %rF	-40 °C...+ 125 °C / 0...100 %rF
<b>Sensor type and length</b>	InPro-CT- 50 = 50 mm InPro-CT-100 = 100 mm InPro-CT-150 = 150 mm InPro-CT-200 = 200 mm	InPro-CF- 50 = 50 mm InPro-CF-100 = 100 mm InPro-CF-150 = 150 mm InPro-CF-200 = 200 mm	InPro-CTF- 50 = 50 mm InPro-CTF-100 = 100 mm InPro-CTF-150 = 150 mm InPro-CTF-200 = 200 mm
<b>Response time</b>	T90 / 20 s	T90 / 4 s	T90 / 20 s, T90 / 4 s
<b>Accuracy Temperature</b>	+/- 0,3 °C @ 25 °C +/- 0,025 °C/°C		
<b>Accuracy Humidity</b>	+/- 2 % @ 10 ... 90 %rF, +/- 4% @ < 10%rF and > 90%rF		
<b>Protection class</b>	IP66 acc. to IEC 60529		
<b>Material thermowell, protection tube</b>	Stainless steel 1.4305, at length 50 mm in plastic max temperature 80°C (room temperature)		
<b>Filter element</b>	at humidity probe with plastic filter element pore size 100 µm		
<b>Ambient temperature/-humidity</b>	- 40...+ 125 °C / 0...100 % rF		
<b>Storage temperature</b>	- 40...+ 125 °C		
<b>Delivery</b>	1 InPro... probe with fast connection and gasket (EPDM) for duct installation		
<b>Installation area probe</b>	safe area (non Ex-area)		

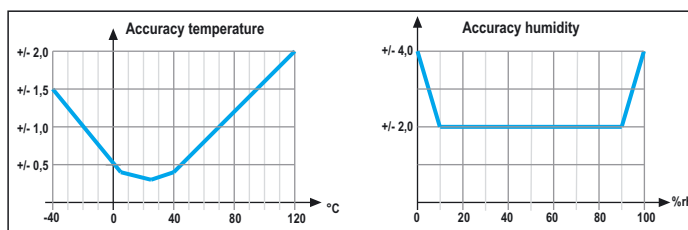

## Values

U = 5 V  
I < 0,5 mA

## Accessories

- MFK** Flange for duct mounting, for variable depth of immersion in ducts.
- TH-VA** Immersion sleeve stainless steel V4A 1.4571, length 120 mm. other length on request.
- FA-VA** Filter element stainless steel, pore size 10µm **not for high humidity!**
- MKR** Mounting bracket for duct Ø 600 mm.

**What is a InPro-probe?**

A InPro probe is a sensor head resp. measuring element which is in combination with a InCos-D transducer for temperature-, humidity or combi temperature/humidity measuring. InPro probes are only for use with InCos-D... transducer. The connection should be done with a socket on the front resp. on the back side of the transducer but only 1 InPro module can be used.

**Dimensions**

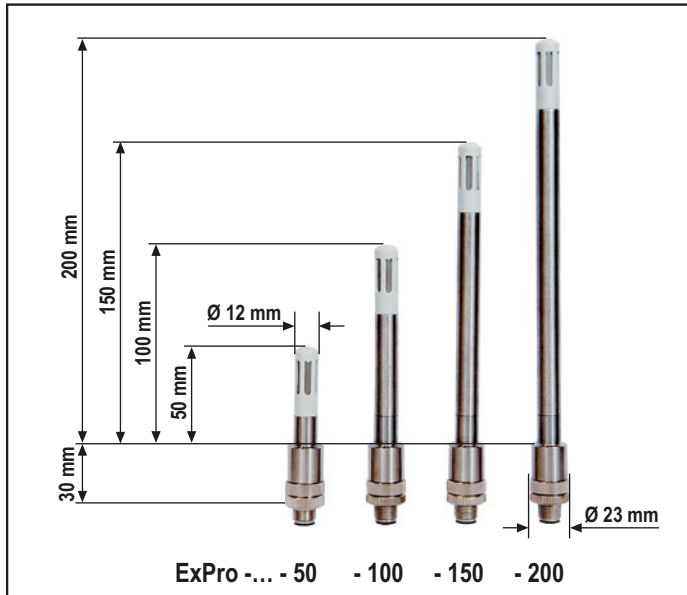

**Important informations for installation and use**

**A. InPro Probe**

The power of the InPro probe is supplied via sensor circuit from the InCos-D. Unused probe-entries at the InCos-D have to be closed with the black caps.

**B. Temperature-flow**

In case of temperature measuring over the max. allowed environmental temperature of 50 °C of the transducer, it has to be watched, that no temperature flow over the probe takes place.

The mounting of the probe has to make sure, that mistakes due to heat-dissipation are within the tolerance-limits and the max. allowed environment temperature is not exceeded.

**C. Mounting**

The probe is being screwed into the socket of the InCos-D. The probe cannot be opened, as parts of the element are moulded. A small distance tolerance between InCos-D (transducer) and InPro (probe) has to be accepted due to production conditions.

**Mounting duct probe (Back side InCos-D)**



For mounting the probe plug the socket and screw on the sensor by turning the lower knurled thumb clock wise. Just screw hand tight. A small clearance between InCos-D (transducer) and InPro (probe) has to be accepted due to production conditions.

**Mounting flange (MFK) for duct installation**

The flange is moved over the probe and fix it with the side wise adjusting screw. The flange can be mounted with the 4 screws direct to the duct.

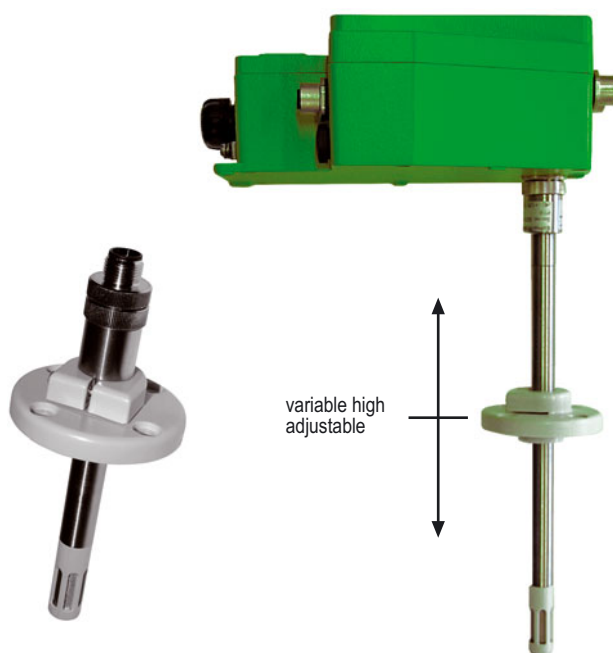

**Mounting room probe (terminal box side InCos-D)**



For mounting the probe plug the socket and screw on the sensor by turning the lower knurled thumb clock wise. Just screw hand tight. A small clearance between InCos-D (transducer) and InPro (probe) has to be accepted due to production conditions.