

InRun Valve actuator on-off, 3-pos, 3-pos-P, 3-pos-U

Electrical, linear actuators – from 500 N to 10.000 N
24-230 VAC/DC, 5-60 mm stroke

InRun - 5.10
InRun - 25.50
InRun - 75.100
InRun - ... - X
InRun - ... - P
InRun - ... - S
InRun - ... - U
InRun - ... - CTS

Subject to change!

Compact . Easy installation . Universal . Cost effective . Safe

Type	Force	Supply	Motor running time	Control mode	Feedback	Wiring diagram
InRun - 5.10	0,5 kN / 1,0 kN	24..230VAC/DC	2 / 3 / 6 / 9 / 12 s/mm	On-Off, 3-Pos	-	SB 1.0
InRun - 25.50	2,5 kN / 5,0 kN	24..230VAC/DC	2 / 3 / 6 / 9 / 12 s/mm	On-Off, 3-Pos	-	SB 1.0
InRun - 75.100	7,5 kN / 10 kN	24..230VAC/DC	4 / 6 / 9 / 12 / 15 s/mm	On-Off, 3-Pos	-	SB 1.0
InRun - ... - X	Type as above but <u>without</u> possibility to assemble external aux. switches (InSwitch)					SB 1.0
InRun - ... - P	Type as above but with additionally feedback potentiometer			On-Off, 3-Pos	Potentiometer 1000 Ohm	SB 1.7
InRun - ... - U	Type as above but with additional feedback 0..10V / 4..20 mA			On-Off, 3-Pos	0..10 V / 4..20 mA	SB 5.0
InRun - ... - S	Type as above but with additionally 2 integrated potential free aux. switches (fix set points), max.24V/1A, 230V/0,25A					SB 3.5
InRun - ... - CTS	Type as above but with amercoat painting, outside parts in stainless steel, cable glands nickel-plated					

Product views / Application



Side view



Back view with terminal box



Front view



Actuator mounted on valve



Compact body

Description size S Highlights

The new InRun valve actuators are a revolution for safety, control valve and other motorized applications for HVAC systems, in chemical, pharmaceutical, industrial and Offshore-/Onshore plants, for use in safe areas.

IP 66 protection, small dimensions, only 7 kg weight, universal functions and technical data, an integrated heater guarantee safe operation even under difficult environmental conditions. High quality brushless motors guarantee long life.

All actuators are programmable and adjustable on site. Special tools or equipment are not required. 5 motor running times and 2 forces as - according to the actuator type - are selectable or adjustable on site. The integrated universal power supply is self adaptable to input voltages in the range of 24 to 230 VAC / DC.

The actuators are 100% overload protected and self locking. The modular concept offers the possibility to mount adjustable end switches for signalization. (except version InRun -...- X). InRun -...- P actuators are additionally equipped with a feedback potentiometer. InRun -...- U is a 3 Pos. actuator but additionally equipped with an analogue output 0..10 V / 4..20 mA. The InRun -...- S has integrated aux. switches (fix positions)

- ▶ Industrial actuators
- ▶ Universal supply unit from 24 to 230 V - AC/DC
- ▶ Selectable forces (0,5 - 1,0 kN) (2,5 - 5 kN) (7,5 - 10 kN), acc. to type
- ▶ Selectable motor running times (2-3-6-9-12 s/mm) resp. (4-6-9-12-15 s/mm) acc. to type
- ▶ On-Off, 3-Pos, 3-Pos-P with potentiometer, 3-Pos-U with 0..10 V / 4..20 mA feedback
- ▶ 0,5 - 1,0 - 2,5 - 5,0 - 7,5 - 10 kN actuator in only one housing (size S)
- ▶ 100 % overload protected, self locking
- ▶ Mechanical stroke limitation, 5..60 mm adjustable
- ▶ Adjustable feedback gear unit for strokes 10 / 20 / 30 / 60 mm
- ▶ integrated junction box
- ▶ Compact design and small dimension (L x W x H = 298 x 208 x 115 mm)
- ▶ Robust aluminium housing (optional marine painting „Amercoat“)
- ▶ IP 66 protection
- ▶ Manual override included
- ▶ Only 7 kg weight
- ▶ Integral safety temperature sensor
- ▶ Status indication by LED

Technical data	InRun-5.10 (basic type)	InRun-25.50 (basic type)	InRun-75.100 (basic type)
Force (nominal)	0,5 / 1,0 kN selectable	2,5 / 5,0 kN selectable	7,5 / 10 kN selectable
Force (blockade) approx.	0,8 / 1,5 kN	4,0 / 7,5 kN	12 / 16 kN
Dimension of external force	0,4 / 0,8 kN	2,0 / 4,0 kN	6,0 / 8,0 kN
Supply voltage/Frequency	24...230 VAC/DC + 15/- 20 %, 50...60 Hz +/- 20 %		
Power consumption	max. starting currents see table "EL" (in acc. with voltage, I _{start} >> I _{rated})		
Heater consumption	approx. 16 W, (motor is not running in this moment)		
Stroke	5...60 mm adjustable		
Motorlaufzeiten	2 / 3 / 6 / 9 / 12 s/mm selectable	2 / 3 / 6 / 9 / 12 s/mm selectable	4 / 6 / 9 / 12 / 15 s/mm selectable
Motor	Brushless DC Motor		Brushless DC Motor
Control mode	On-Off and 3 Pos.		
Electrical connection	Junction box incl. terminals 0,14...4 mm ²		
Cable gland	M20 × 1,5 cable diameter Ø 6...13 mm		
Manual override	Change from auto to hand mode with sidewise (red) switch and turn with the allen key top side		
Housing material	Aluminium die cast housing, painted (optional marine coating type ...-CTS)		
Dimensions	L × W × H = 298 × 208 × 115 mm, for diagram see extra information „ME-R“		
Weight	ca. 7 kg Standard version without adaption		
Ambient temperature	-20...+ 50°C		
Storage temperature	-40...+ 70°C,		
Humidity	0...95 %rF non condensing		
Operation mode	S3/50 % ED = duty cycle (max. 600 operating cycles / h)		
Accuracy mechanically	< 1 mm stroke (hysteresis)		
Accuracy electrically	approx. 100 steps acc. to adjusted stroke e.g. 10 mm stroke = 0,1 mm resolution		
Parameter at delivery	500 N, 6 s/mm	2,5 kN, 6 s/mm	7,5 kN, 9 s/mm
Delivery	Actuator with integrated junction box, allen key for manual override		
Wiring diagrams (SB)	SB 1.0	SB 1.0	SB 1.0

Deviate Data	InRun-5.10-X	InRun-25.50-X	InRun-75.100-X
Actuator InRun-...-X	as basic type, but without possibility to assemble external aux. switches		
Wiring diagrams (SB)	SB 1.0	SB 1.0	SB 1.0

Deviate Data	InRun-5.10-S	InRun-25.50-S	InRun-75.100-S
Actuator InRun-...-S	as basic type, but incl. two fix adjusted aux. switch switch points at 0 - 10 - 20 - 30 - 60 mm acc. to gear belt setting		
Max values aux. switches	24 V / 1 A 230 V / 0,25 A (min. 10 mA)		
Wiring diagrams (SB)	SB 3.5	SB 3.5	SB 3.5
	aux. switch setting acc. to stroke, note page 4		

Deviate Data	InRun-5.10-P	InRun-25.50-P	InRun-75.100-P
Actuator InRun-...-P	as basic type, but incl. feedback potentiometer by gear belt adjustable for max. resolution at 10 - 20 - 30 - 60 mm		
Potentiometer	1 kOhm		
Wiring diagrams (SB)	SB 4.0	SB 4.0	SB 4.0
	Feedback signal potentiometer acc. to stroke setting, note page 4		

Deviate Data	InRun-5.10-U	InRun-25.50-U	InRun-75.100-U
Actuator InRun-...-U	as basic type, but incl. feedback signal U by gear belt, adjustable for max. resolution at 10 - 20 - 30 - 60 mm		
Feedback signal U	0...10 VDC, 4...20 mA acc. on wiring selectable on site, U _u 0...10 VDC @ 1.000...∞ Ω, U _i 4...20 mA @ 0...800 Ω		
Wiring diagrams (SB)	SB 5.0	SB 5.0	SB 5.0
	Feedback signal V / mA acc. to stroke setting, note page 4		

Approvals	
EMC	RL 89/336/EC
Low voltage	RL 73/23/EC
Protection class	Protection class I (grounded)
IP-Protection	IP 66, in acc. with EN 60529

Accessories or special solutions	
...-CTS	marine coating (Amercoat), parts in stainless steel, cable gland nickel plated
InSwitch	2 external aux. switches, adjustable, for zone 1, 2, 21, 22
InBox-SW	Ex-e junction box for aux switches InSwitch zone 1, 2, 21, 22
MKK-S	mounting bracket in VA for terminal boxes type InBox-... direct on actuator
GMB-1	Rubber bellow
Adaptions	for fittings and manufacturer on request

Electrical connection

All actuators are equipped with an universal supply unit working at a voltage from 24 to 230 VAC/DC. The supply unit is self adjustable to the connected voltage! Device must be fuse protected max. 5 AT. Note current consumption acc. to running time and applied voltage. Do not open the junction box when circuit alive.

Parameter, Adjustment – Failure indication

Switch – Push button – Lamp for adjustment, behind the blanking plug

- 10-position switch (S)
- Push button (T)
- 3-colour LED

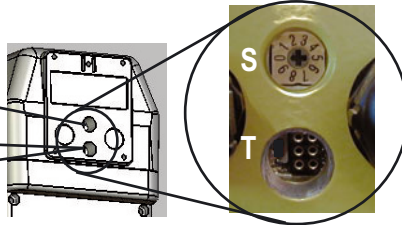

Parameter selection

Example:
InRun-25.50

Type	Forces		Forces	
..Run -5.10	500 N	1.000 N		
..Run-25.50	2.500 N	5.000 N		
..Run-75.100			7.500 N	10.000 N

Requested parameter:
Force 5000 N
stroke/s 6 s/mm

Running times	Pos. of switch	Running times	Pos. of switch
2 s/mm	00	4 s/mm	00
3 s/mm	01	6 s/mm	01
6 s/mm	02	9 s/mm	02
9 s/mm	03	12 s/mm	03
12 s/mm	04	15 s/mm	04

Result:
switch position (S) 07

Function, adjustment and parameter

A) Self adjustment:
Push button T for min. 3 seconds. The actuator will drive into both end positions to be adjusted. LED indicates green blinking. The adjustment drive could be applied in any switch position (S).

B) Selection of running time and force:
Put 10 position switch (S) into the correct/selected position in acc. to above table. The selected parameter will work at next operation of the actuator. Adjustment can be done even without supply voltage. If supply voltage is available turn switch only if actuator is not running.

C) Additional information for 3-pos operation:
a closed, b open = rod goes IN
b closed, a open = rod goes OUT
a and b closed = Motor doesn't work, No function
a and b opened = Motor doesn't work, No function

D) Force in blocking position:
The force in the end position could be much more than the nominal force. Generally the valve is to check together with actuator and construed accordingly.

Wiring diagram InRun- / InRun-...-X

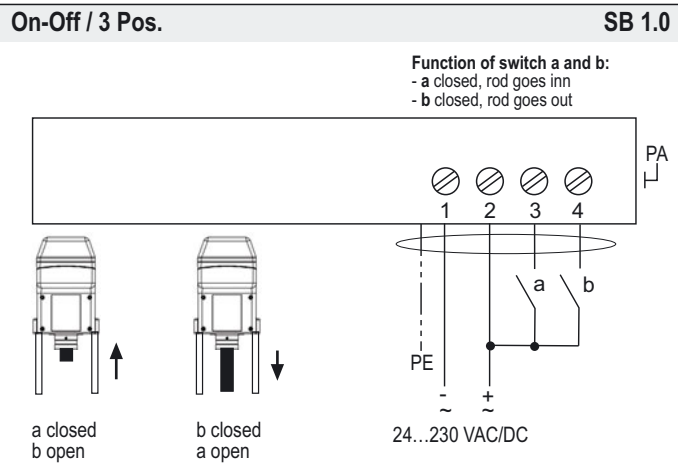

Wiring diagram InRun-...-S

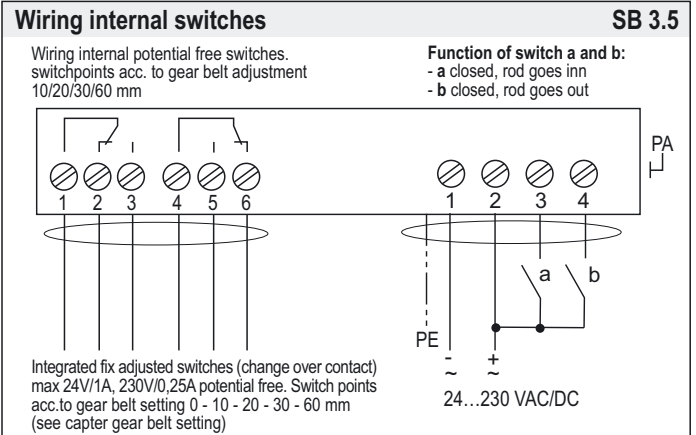

Wiring diagram InRun-...-P

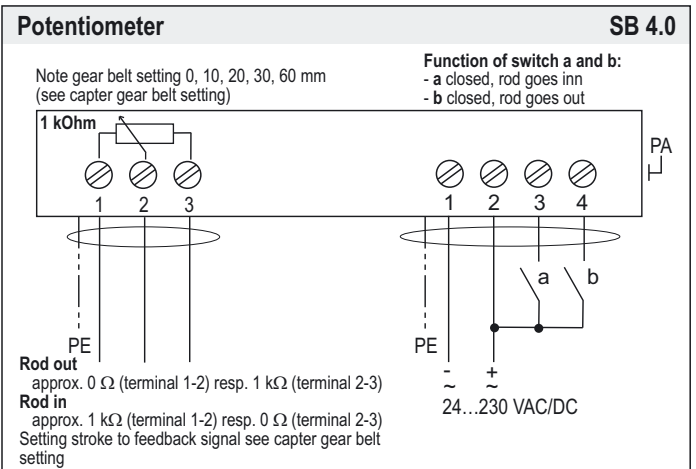

Wiring diagram InRun-...-U

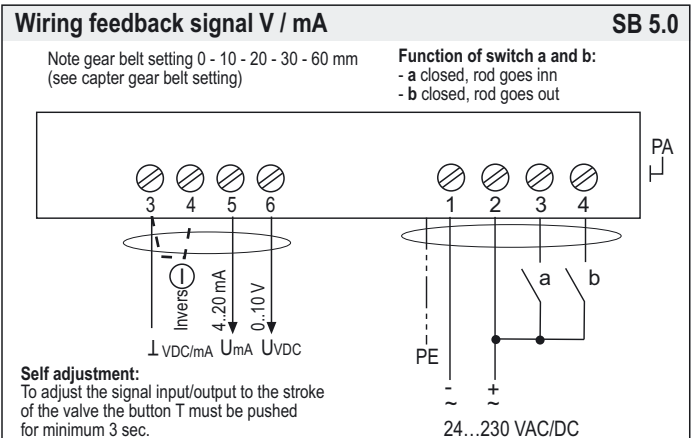

Junction Box

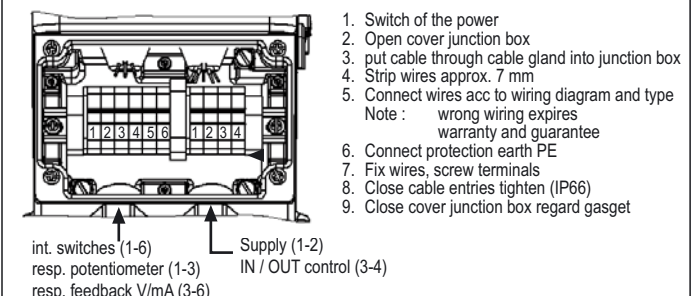

Mounting instructions and important information for operation and installation

Manual Override

1. Actuator must be in stop position
2. Turn „red“ switch from motor to hand mode
3. Turn with allen key to needed stroke (top side)
CW = rod OUT
CCW = rod IN
4. After finishing turn back to motor mode

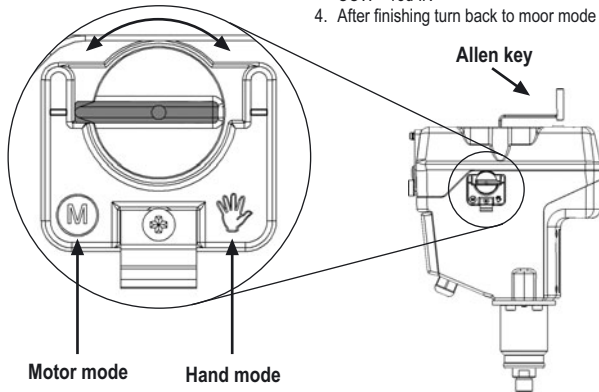

Safety notes



Supply
24...230 V AC/DC

Version InRun-...-S
limit switches 24V / 1A 230V/0,25A
or
Version InRun-...-P
potentiometer 0-1000 Ohm
or
Version InRun-...-U
feedback 0-10V/4-20 mA

- Do not open the cover when circuit alive
- The cable must be installed in a fixed position and protected against mechanical damage
- Connect potential earth.
- Avoid temperature transfer from valve to actuator (note max. ambient temperature !)
- Ambient temperature -20...+ 50°C
- Close all openings with min IP66
- Regard all regional standards, rules and regulations.
- For outdoor installation a protective housing against rain, snow and sun should be applied to the actuator, as well as a constant supply at terminal 1 and 2 for the integral heater.
- Use for wiring the integrated junction box
- Actuators are maintenance free

Accessory InSwitch – adaptable external aux. switches



InSwitch is an accessory to InRun actuators, fixing directly onto the actuator. InSwitch are aux. switches with with 2 potential free contacts, adjustable on site. The electrical wiring needs an terminal box InBox-SW. Switches has approx 1 m cabl. (see ..Switch data sheet)

Extra information „EL-R“ (see additional data sheet)

extra technical information, versions of circuit diagrams and failure indication

Extra information „ME-R“ (see additional data sheet)

extra technical information, dimensions, installation instruction and illustration

1. Demounting cover for stroke adjustment/limitation

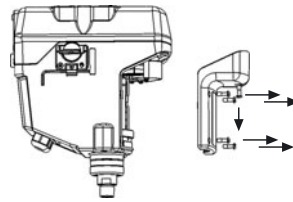

Switch off power.

5 × open screw before remove cover.

Note cover gasket must be fit in the groove after remounting.

2. Adjust stroke

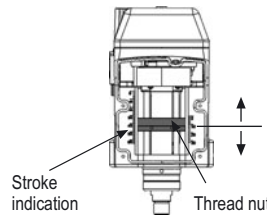

Stroke can be adjusted by thread nut from min 5 mm to 60 mm.

3. Open cover bracket feedback gear

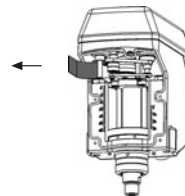

If open cover bracket gear belt is removed from tension after this choose the right setting acc. to stroke by hand – not use any tools.

4. Gear belt adjustment for internal switches resp. potentiometer

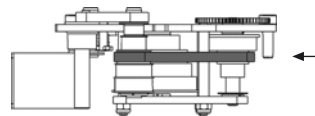

If open cover bracket gear belt is removed from tension after this choose the right setting acc. to stroke by hand – not use any tools.

Internal switches acc to . gear belt setting adjust the switch points lower / higher limit.

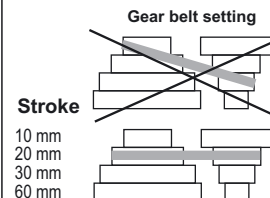

setting	switch points at	
10 mm	0-1 mm	10-11 mm
20 mm	0-1 mm	19-20 mm
30 mm	0-1 mm	28-30 mm
60 mm	0-1 mm	55-60 mm

Note: there is no possibility to adjust interim values only with InSwitch (accessory).

Potentiometer adjust the feedback signal (0-1000 Ohm) to stroke

5. Close cover bracket for feedback gear setting

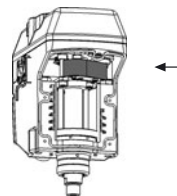

Note right position of gear belt.

Close bracket thereby the gear belt is automatically tensioned.

6. Remounting cover

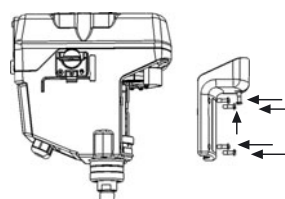

5 × fix screws tighten.

Note cover gasket must be fit in the groove after remounting.

Switch on power.



..Run – extra information EL-R



The „EL-R“ data sheet contains additional information for ..Run actuators of the size S, for the optimization and simplification in regard to planning, installation and initial startup. It provides influences of external factors in reference to the safe initiation of the actuators, as well as technical references and problem solutions (error indication). With the error indication, functions can be examined and different error/problems can be adjusted locally.

- ▶ Power supply design
- ▶ Design of line cross section 24...48 VAC/DC
- ▶ Error indication – problem treatment/solution

For additional mechanical data have a look at extra information „ME-R“

Power input depending of supply voltage

Power supply design

The design of the on-site supply, depends on the selected motor running time and selected supply voltage. Accompanying values are „about values“, since there can be construction unit dispersions within electronics. The power consumption in the blocking position is run time independently with max. 20 W. The power consumption for the heater is approx. 16W. The heading is running only if the motor is in idle position! The initial starting supply voltage required by the actuators power supply unit is around 2,0 A for about 1 sec. (Please consider this while conceiving the cross section of the supply line)

- Electrical connection with approved terminals only
- Electrical connection with integrated junction box. After this close all openings and screws thighten.
- Do not open the junction box when circuits alive!
- The cable of the actuator must be installed in a fixed position and protected against mechanical and thermal damage.
- The cross section of the wiring please choose according the length of the wiring and the necessary power consumption of the actuator. Too small cross sections are very often the reason for malfunctions.
- Power connection must be made with switched off circuits, always.
- Note supply voltage! Wrong connection or over voltage are no warranty!
- Inrush current is approx. 2 A up to 1 sec. Please note during dimensioning.

Load	Rated current in acc. with motor running time									
	500 N					1.000 N				
Voltage	2	3	6	9	12	2	3	6	9	12
24 V I _{Nenn} [A]	0,5	0,4	0,3	0,4	0,3	1,0	0,8	0,6	0,5	0,5
120 V I _{Nenn} [A]	0,4	0,3	0,2	0,1	0,1	0,4	0,3	0,2	0,1	0,1
230 V I _{Nenn} [A]	0,3	0,2	0,1	0,1	0,1	0,3	0,2	0,1	0,1	0,1

Load	Rated current in acc. with motor running time									
	2.500 N					5.000 N				
Voltage	2	3	6	9	12	2	3	6	9	12
24 V I _{Nenn} [A]	0,6	0,5	0,3	0,3	0,3	0,9	0,6	0,4	0,3	0,3
120 V I _{Nenn} [A]	0,4	0,3	0,2	0,1	0,1	0,5	0,4	0,4	0,3	0,3
230 V I _{Nenn} [A]	0,3	0,2	0,1	0,1	0,1	0,3	0,2	0,1	0,1	0,1

Load	Rated current in acc. with motor running time									
	7.500 N					10.000 N				
Voltage	4	6	9	12	15	4	6	9	12	15
24 V I _{Nenn} [A]	1,2	1,0	0,8	0,6	0,4	1,5	1,2	1,0	0,7	0,5
120 V I _{Nenn} [A]	0,5	0,5	0,4	0,3	0,3	0,5	0,4	0,4	0,4	0,3
230 V I _{Nenn} [A]	0,5	0,5	0,4	0,4	0,3	0,6	0,5	0,4	0,4	0,2

Dimensioning of the line cross section with 24...48 VAC/DC supply voltages

Dimensioning/Design of the supply line

On long distances between voltage supply and drive, voltage drops occur due to line resistances. As a consequence with 24 VAC/DC the actuator receives a too low tension and does not start. In order to prevent this, the cross section of the inlet line is to be designed/dimensioned accordingly. The accompanying formula allows the calculation of the necessary line cross section, perhaps provides the maximally permitted conduit length utilizing the existing line cross section. Alternatively the secondary voltage can be increased by selecting a transformer. For calculation purposes, following characteristics are essential:

Uv = supply voltage in [V]

A = line cross section in [mm²]

L = conduit length in [m]

Factor 0.0714 = drive-specific factor [Vmm²/m] (based on the electrical conductivity of electrolytic copper with a coefficient of 56m/Wmm²)

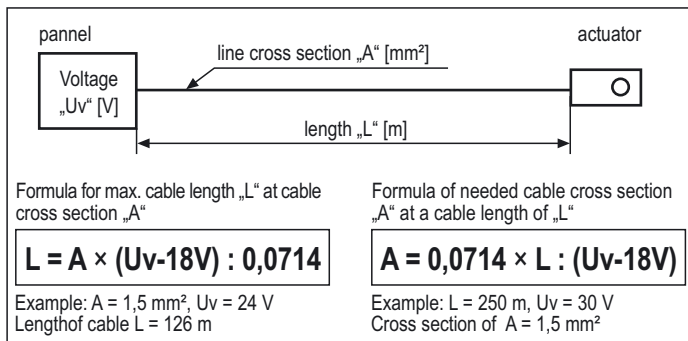

Example:
24 V power supply with wire diameter 1,5 mm² = 126 m

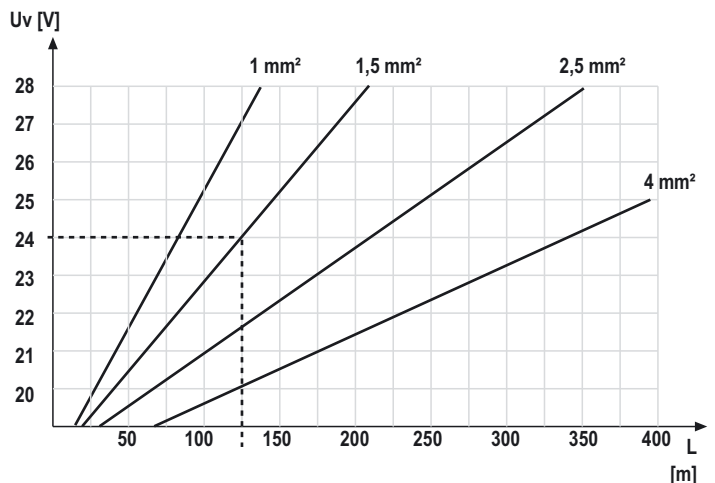



Technical requirements for controller

The controller must ensure that the following conditions are fulfilled: To ensure a high accuracy and long life, the actuators are equipped with "protective mechanisms". They protect all electric motors against early wear. For 2 and 3-point actuators, a minimum control time of 1,0 seconds must be attained. If your controller pulses in short steps (<1.0 sec), the actuator will not respond. Intervals < 1.0 seconds are an indication that the feedback loop has not been designed correctly in correlation with the Schischek actuators.
Note at small control deviations is the actuator permanently active what can arise overtemperature and the actuator goes in stop position. This self protection is a sign that the control loop is incorrect.

Maintenance

In acc. with operation actuators are maintenance free. Nevertheless maintenance must comply with regional standards, rules and regulations. The actuator can be open for adjustments only. After settings all covers must be closed. Damaged junction box, cable glands or gasgats must be changed to original parts or send for repair to Schischek GmbH.

Service and Commissioning

- Ensure that the supply voltage is in accordance with the specifications
 - Before switch on power check the wiring
 - Connect protection earth and potential equalisation.
 - The actuator must not display any type of mechanical damage
 - Rod goes in with contact 3 to 2
 - Rod goes out with contact 4 to 2
 - Check manual override
- Check options:**
- Check internal aux. switches regarding endposition
 - Check feedback potentiometer
 - Adjust external switches note
- Further checks**
- Check valve and actuator linkage to confirm correct connection
 - Check the terminal box for damage
- With manual override you move the rod very carefully in the end positions. Actuator and valve can be damaged
Before switching off, consider the effects on the system and on other devices. Disconnect the mains before starting mechanical dismantling. The junction box must be free of voltage. Loosen the linkage and remove the actuator.

Error indication

Error/Symptom	Reason	Solution
01 Actuator does not work LED does not lights	<ul style="list-style-type: none"> ● No power supply attached ● The actuator is operated beyond prevention ambient temperature specifications and the internal temperature sensor did irreversibly shut down operations 	<ul style="list-style-type: none"> ● Attache power supply and turn on ● Because of inadmissible operation the actuator drove out of safety relevant reasons into an irreversible condition and must be exchanged. Accompanying new installation the ambient temperature has to be reduced accordingly
02 Actuator does not work LED lights red	<ul style="list-style-type: none"> ● The actuator is operated by a too high ambient temperature and the internal temperature sensor responded 	<ul style="list-style-type: none"> ● Shut off actuator and let temperature decrease, reduce ambient temperature by suitable measures e.g. ventilation or other mounting position of the actuator
03 Actuator does not work LED lights green	<ul style="list-style-type: none"> ● 3-Pos control signal is wired on both entrances ● Required force is greater than actuators force ● Control signals are not attached or attached on a wrong conductor ● Actuator is incorrect mounted and is blocked by an external stop unit ● Actuator is clogged with more than 20 impulses < 0,5/sec. and therefore adjusted into suspend mode ● Interchanged supply lines 	<ul style="list-style-type: none"> ● Readjust/correct circuit ● Adjust a higher force at the actuator if possible otherwise exchange for a type with higher force. ● Examine rule and adjusting signal in accordance with attached diagram ● Dismount actuator and testdrive without load for operability. Install actuator accordingly that the power transmissions runs without external blockade or torsion ● Switch off supply voltage for at least 2 sec. thereby a reset is conducted Readjust controller in order to extend control pulses ● Wire 1 must be (-, N) and wire 2 (+, L)
04 Acuator does not work LED is red blinking	<ul style="list-style-type: none"> ● The actuator has been mounted by temperatures of less than -20°C and did not reach is operating temperatur of at least -20°C. 	<ul style="list-style-type: none"> ● Ensure that a constant voltage supply on conductor 1--2 is existing. ● Wait until the required operating temperature is achieved by the actuators internal heating system. The actuator will start operating independently
05 LED flashes irregularly and actuator does not work	<ul style="list-style-type: none"> ● Actuator does not receive sufficient supply voltage ● Cable to long, voltage drop in the supply line to large 	<ul style="list-style-type: none"> ● Increase line cross section or increase tension at the transformer/power supply unit ● Increase line cross section or increase tension
06 LED flashes red and endposition is not reached	<ul style="list-style-type: none"> ● Actuator is in blocking position 1 × blinking block position rod goes in 2 × blinking block position rod goes out 	<ul style="list-style-type: none"> ● External load is higher than actuator max force Check mechanic of easy going and twisting check probably without valve



..Run extra information ME-R



The „ME-R“ data sheet contains additional information for ..Run actuators of the size s, for the optimization and simplification in regard to planning, installation and initial start up. It provides influences of external factors in reference to the safe initiation of the actuators. In particular it represents the installation, as well as different and armatures. Additionally describing different accessory elements and their mounting to the actuator.

- ▶ Dimension, drill template
- ▶ Control elements: switch – push button – LED
- ▶ Outdoor installation
- ▶ Mounting adaption

For additional electrical data have a look at extra information „EL-R“

Dimensions – drill template

Dimension size S

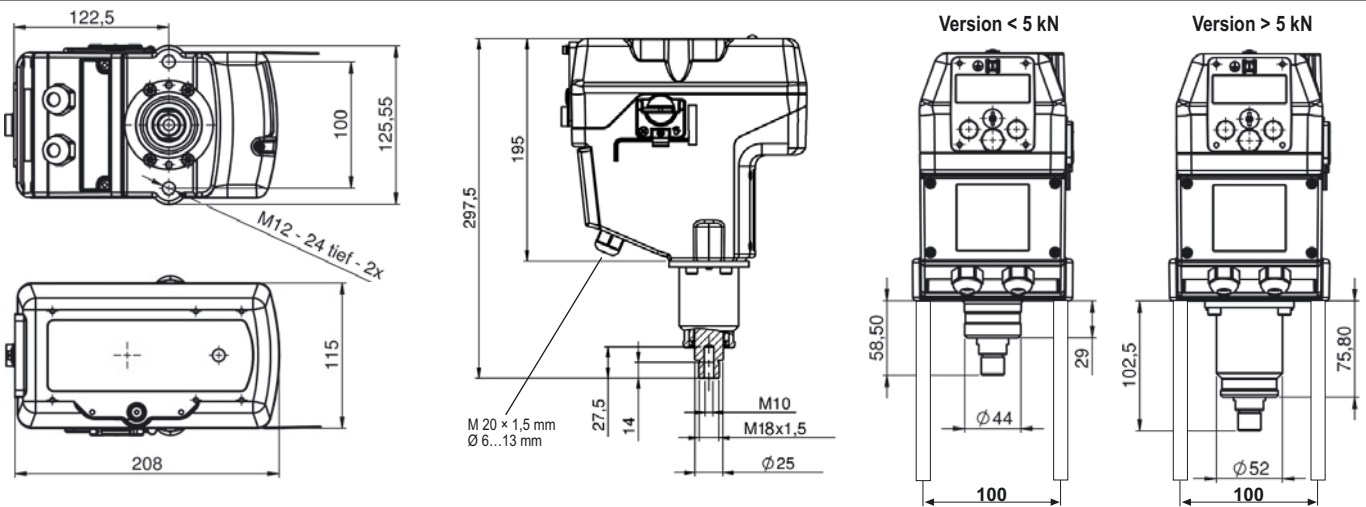

Measurements in mm

Control elements: switch – push button – LED

Specification

All actuators are equipped with a 10 position switch a push button and a multicolor LED for calibration. These control elements are to be found cable-laterally behind the two middle sectioned dummy plugs. For operation these must be removed. The calibration can be achieved despite lining up tension at the actuator. The function is not impaired thereby. However it has to be of great concern that the dummy plugs must be rescrewed in order to comply with the IP-protection class. The operation of the switch and button has to be done by means of a small screwdriver. Force with strong pressure and /or rotation is to be avoided in any case, since otherwise control electronics can be damaged irreparably. By bad visibilities a flashlight (certified within the EX-range) should be used. Attitudes of torque and running time can be achieved also before mounting. The adjustment of stroke can be started only with accurate mounting to the valve.

Switch – push button – LED for programming, behind plug

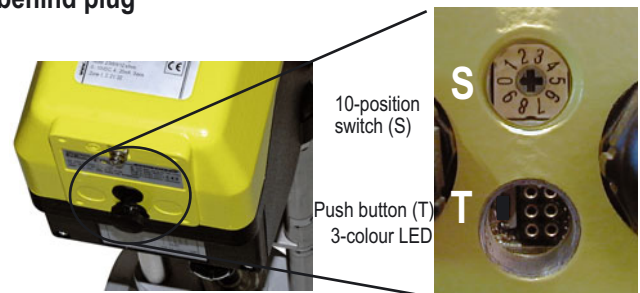

Outdoor installation or high dust loading

Description

When mounting actuator outdoors it has to be certain that the actuator is protected against direct sun exposure (heat and UV), rain and snow by employing an enclosure roof. Supply voltage is to be applied immediately after mounting in order to assure integrated heating at start. All actuators has an internal safety temperature limiter, these may not be exposed neither at storage nor during operation to a too high temperature. Otherwise the limiters could respond and switch of the actuator irreversibly. At high dust loading prevent the rod.

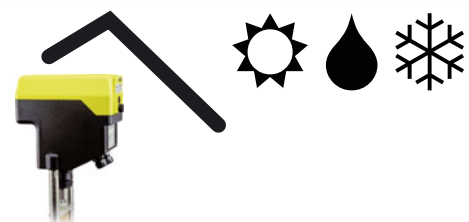



Mounting instruction for ..Run

Specification Mounting Position

- When mounting particularly observe the following:
- The linkage spacer columns for the actuators should only to be mounted vertically (Sketch).
 - Valve actuators should only be mounted as shown opposite, never suspended.
 - When mounting on a steam valve, the actuator should not to be mounted vertically above the valve as the rising heat could result in a part of the actuator being damaged.
 - If mounting outside or in areas with a high level of humidity, the drive must be equipped with a heater
 - Vibration should be avoided, they shorten the serviceable life of the actuators
 - Pressure fluctuations in steam systems must be avoided, suitable shock absorption should be incorporated to protect the actuator.

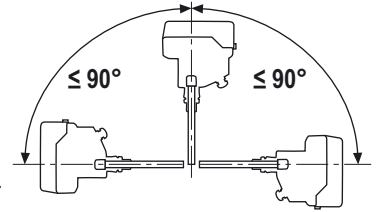

The valve adaption

For mounting and adjustment, act as follows:

- The actuator needs a specific linkage to match the selected valve.
- The actuator is mounted on the valve by way of the valve linkage.
- Check the stroke of actuator and compare with valve if necessary adjust stroke
- Check adaptation
- Mount actuator to valve

Stroke setting

The max. stroke is 60 mm. To reduce this turn the adjusting screw. Open the lateral cover of actuator. Remove the 5 screws of the cover and set the adjusting screw of needed stroke. (see ..Run data sheet page 4)

1. The actuator will be delivered with retracted stroke.
2. Place the actuator on the valve body and attach with the nuts and washers provided.
3. Remove the cap nut (2) and screw the connecting parts with the connecting nut (3), taking care not to damage the valve spindle. The spindle should be retracted as far as possible into the valve body.
4. Allow enough distance between the threaded bolt head (4) and the rod of the actuator, **noting the travel of the valve spindle**. Any adjustment can be done by screwing the bolt (4) into the connection nut(3).
5. Screw the nut (5) hand tight. Draw out the valve spindle with the connecting parts until contact is made to the threaded actuator rod and join with the cap nut (2). **Do not overtighten (max. 4 Nm) otherwise damage will be cause to the mounting bracket.**
6. Connect the actuator to the supply in accordance with the wiring diagram.
7. Operate the actuator electrically to fully extend the actuators rod. For modulated controlled actuator with a 4 mA or 0 VDC positioning signal or by connecting to load via terminal 4 (if no positioning signal available). Visual check that the valve is closed. Minor adjustment to the travel can be achieved by turning the threaded bolt (4).
8. connections, take care not to operate the actuator against the stroke otherwise damage to mounting bracket may occur.
9. Start adjustment drive
10. The actuator is ready to operate.

Mounting of ..Switch

Check adaptation on 2/3 way valve

- Check adaptation on 2 way valve**
- Check adaptation
 - Mount adaption to actuator
 - Set stroke note internal and external end positions
 - Push button (T) for 3 sec (necessary for Y "modulation" types)
 - Actuator goes automatically in the adjusted end position and scale the stroke.
- Check adaptation on 3 way valve**
- An adaption on a 3-way valve is checked as above. You only need to take into account that the lift rod must move to both of the valve closures. This can necessitate a repeated check or adjustment.

- Fixing the valve stroke in position**
- With 3-way valves, the valve stroke must be less than the actuator stroke. The valve stroke must be measured exactly so as to eliminate ± tolerances. The actuator stroke must be slightly greater than the valve stroke (3-way valves close in two directions). For 2-way valves it is possible to use the value stated in the written information. However, many valve manufacturers do not allow travel beyond its fully open/closed position (2-way valves only close in one direction).

Specification

- Plug adaption in actuator shaft
- Plug on ..Switch and screw
- Additional junction box ..Box-SW for wiring necessary
- Open cover of Switch and set the switch points (see data sheet ..Switch)
- Check switch points und stroke
- Close ..Switch cover

M.MZ-02.01-S-en extra info ME-R
21-apr-2009