

Duct Humidity Temperature Sensor

Humidity sensor with resistor output 0... 1kOhm and Pt100 passive sensor in hazardous locations zones 1, 2

ATEX compliant

Type TFFK-2G

APPLICATION

TFFK-2G Humidity temperature sensor with resistance output for determining relative humidity and temperature in duct. In combination with EEx-i transducer Type EXL-IMU-1 with intrinsic safe circuit the sensors may be used in hazardous areas zones 1 and 2. The passive resistance output of the sensor is changed into an active signal of 0(2)... 10 V- or 0(4)... 20 mA.

TECHNICAL DATAS

Type	TFFK-2G
Supply	by EEx-i transducer
Sensor	0...1000 Ω / Pt100
	2(3) wire, resistor linear
Accuracy	< 40 % r.F. = ± 3,5 % r.F. > 40 % r.F. = ± 2,5 % r.F.
	Pt100 ± 0,5°C
Measure-, work-range	0...100% r.F., 30...100 % r.F.,
Ambient temperature	-10...+50 °C
Storage temperature	-20...+60 °C
Permitted flow velocity	8 m/s, 15 m/s with protective gauze
Measuring medium	gaseous, pressureless, not aggressive
Connection	Screw clamps 0,5 mm ²
Enclosure	Plastic, IP64, for wall and flush mounting
Sensor	Stainless steel, IP40
Dimension and weight	120 x 80 x 60 mm, approx. 200 g
Protection class	II2G EEx ia IIC T6, acc. to EN50014 / EN50020
	simple apparatus
CE	94/9/EC (ATEX)
Included in price	1 Duct humidity + Pt100 sensor TFFK-2G
Installation area	Hazardous locations in zone 1, 2 with transducer Type EXL-IMU-1

**II2G EEx ia IIC T6
Zone 1, 2
acc. to ATEX**



EEx-i CIRCUITS - TABLE 1

Operation values maximum at terminal

Terminals	1-2-3	4-5-6
Voltage	Ui 9 VDC	9 VDC
Current	Ii 5 mA	5 mA
Power	Pi 10 mW	10 mW
Capacity	Ci < 10 pF	0
Inductivity	Li < 100 μH	0

The maximum values must not be exceeded!
Please check your external capacities and inductivities in acc. to the length of the cable and the methode of installation.

MOUNTING AND INSTALLATION

Notes to mechanical installation. The installation must comply with relevant directives and standards Particularly with regard to:
- Comply with the EMC directive
- Avoid parallel wiring of power cable this cause measurement errors.
- Recommendation: Use shielded cable. Connect shield at PLC or control room area, sensor side is open.

MAINTENANCE

In clean air, the measuring element is maintenance-free. Aggressive and solvent containing agents as per their type and concentration may cause faulty measurements.
Water repellent protective film forming deposits on the sensor, resin aerosoles, laquer aerosoles, smoke deposits etc. are harmful to almost all types of humidity sensors.
The water resistance of the sensors makes it possible to clean them with water, solvents should not be used. Due to long term sensor stability, no re-calibration is necessary. No warranty will be guaranteed if inner parts of the device have been handled.
The probe should be inserted into the medium to a minimum of 170 mm!

RECOMMENDED TRANSDUCER

- Transducer Mfr. Schischek Type EXL-IMU-1.
- In combination with transducer EXL-IMU-1 is intrinsic safety proof for simple circuits given.
- Manufacturer declaration zone 1 and 2.

ELECTRICAL CONNECTION

Humidity Temperature Sensor TFFK-2G

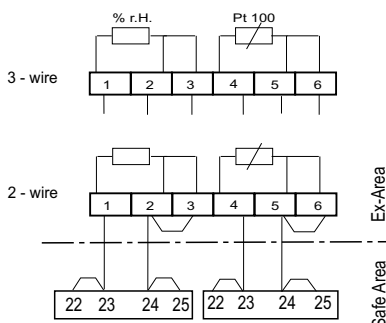

EEx-i Module EXL-IMU- 1 (2 pieces)

DIMENSIONS

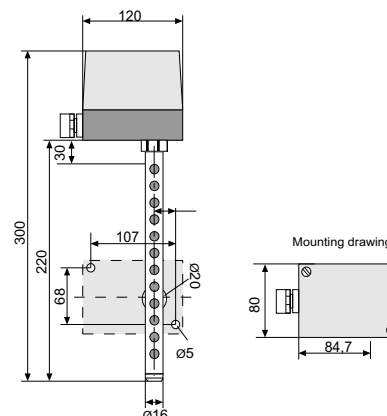

ATTENTION!

- For installation, use and maintenance the official standards and rules must be applied.
- The energy of intrinsically safe circuits are below the level to start an explosion in case of a spark..
- Intrinsic safe circuits must be installed with light blue coloured and separate from non intrinsic safe circuits.
- The sensor is passiv and potential free for use in hazardous locations in zone 1, 2.
- Pay attention to the max values for wiring, listed in table 1.
- Avoid electrostatic discharge.
- Only wet cleaning.

Subject to change