

Room-sensor for Temperature and Humidity

Humidity sensor with resistor output 0... 1kOhm and Pt100 passive sensor in hazardous locations zones 1, 2

ATEX compliant

Type TFFR-2G

APPLICATION

TFFR-2G Humidity temperature sensor with resistance output for determining relative humidity and temperature in rooms. In combination with EEx-i transducer Type EXL-IMU-1 with intrinsic safe circuit the sensors may be used in hazardous areas zones 1 and 2. The passive resistance output of the sensor is changed into an active signal of 0(2)... 10 V- or 0(4)... 20 mA.

TECHNICAL DATAS

Type	TFFR-2G
Supply	9 VDC by EEx-i transducer
Sensor	0...1000 Ω / Pt100
	2(3) wire, resistor linear
Accuracy	< 40 % r.F. = ± 3,5 % r.F. > 40 % r.F. = ± 2,5 % r.F.
	Pt100 ± 0,5°C
Measure-, work-range	0...100% r.F., 30...100 % r.F.,
Ambient temperature	-10...+50 °C
Storage temperature	-20...+60 °C
Connection	Screw clamps 0,5 mm ²
Enclosure	Plastic, IP20, for wall mounting
Dimension and weight	115 x 70 x 43 mm, approx. 200 g
Protection class	II2G EEx ia IIC T6, acc. to EN50014 / EN50020 simple apparatus
CE	94/9/EC (ATEX)
Included in price	1 Room humidity + Pt100 sensor TFFR-2G
Installation area	Hazardous locations in zone 1, 2 with transducer Type EXL-IMU-1 for temperature and one EXL-IMU-1 for humidity

**II2G EEx ia IIC T6
Zone 1, 2
acc. to ATEX**



MOUNTING AND INSTALLATION

Notes to mechanical installation. The installation must comply with relevant directives and standards Particularly with regard to:
 - Comply with the EMC directive
 - Avoid parallel wiring of power cable this cause measurement errors.
 - Recommendation: Use shielded cable. Connect shield at PLC or control room area, sensor side is open.
 Best measuring effect will achieved when air flow vertical through the device. Measuring points beside doors, windows, heating sources or air blower can be irritate the results.

EEx-i CIRCUITS - TABLE 1

Operation values maximum at terminal

Terminals	1-2-3	4-5-6
Voltage	Ui 9 VDC	9 VDC
Current	Ii 5 mA	5 mA
Power	Pi 10 mW	10 mW
Capacity	Ci < 10 pF	0
Inductivity	Li < 100 µH	0

The maximum values must not be exceeded!
 Please check your external capacities and inductivities in acc. to the length of the cable and the methode of installation.

MAINTENANCE

In clean air, the measuring element is maintenance-free. Aggressive and solvent containing agents as per their type and concentration may cause faulty measurements.
 Water repellent protective film forming deposits on the sensor, resin aerosoles, lacquer aerosoles, smoke deposits etc. are harmful to almost all types of humidity sensors.
 The water resistance of the sensors makes it possible to clean them with water, solvents should not be used. Due to long term sensor stability, no re-calibration is necessary. No warranty will be guaranteed if inner parts of the device have been handled.
 The Probe should be inserted into the medium to a minimum of 170 mm!

RECOMMENDED TRANSDUCER

- Transducer Mfr. Schischek Type EXL-IMU-1.
- In combination with transducer EXL-IMU-1 is intrinsic safety proof for simple circuits given.
- Manufacturer declaration zone 1 and 2.

ELECTRICAL CONNECTION

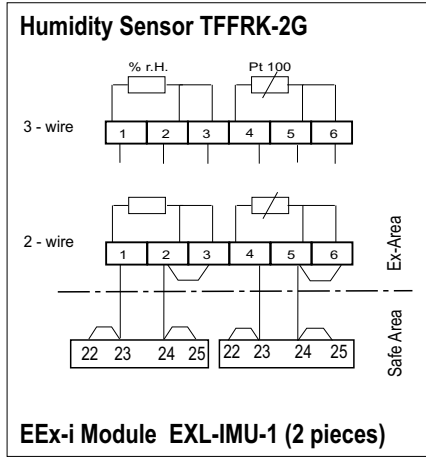

DIMENSIONS

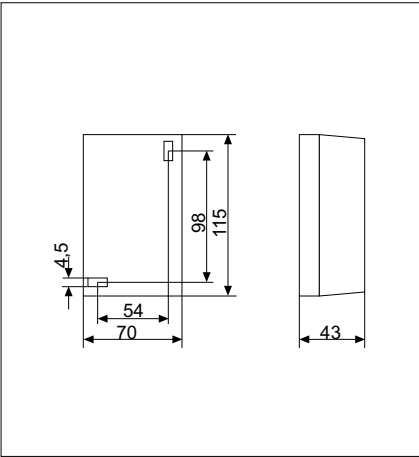

ATTENTION!

- For installation, use and maintenance the official standards and rules must be applied.
- The energy of intrinsically safe circuits are below the level to start an explosion in case of a spark..
- Intrinsic safe circuits must be installed with light blue coloured and separate from non intrinsic safe circuits.
- The sensor is passiv and potential free for use in hazardous locations in zone 1, 2.
- Pay attention to the max values for wiring, listed in table 1.
- Avoid electrostatic discharge.
- Only wet cleaning.